

<u>Project Title</u>	Rapid analytical systems for raw produce quality and safety attributes
Project number:	TF 127 (LINK FQS 12)
Project leader:	Dr R Luxton, University of the West of England (UWE)
Report:	Final report, May 2004
Previous report	6 monthly report, September 2003
Key staff:	Dr R Luxton (UWE) Dr J Hart (UWE) Dr J Groves (Jenway Ltd) Dr D Fournier (University of Perpignan) Dr P Millner (University of Leeds) Mr R Pittson (Gwent Electronic Materials Ltd) Dr G Drago (Applied Enzyme Technology Ltd)
Location of project:	University of the West of England (UWE) University of Leeds (UoL) University of Perpignan (UoP) Jenway Ltd (JW) Gwent Electronic Materials Ltd (GEM) Applied Enzyme Technology Ltd (AET)
Project coordinator:	Dr R Luxton, UWE, Frenchay Campus, Coldharbour Lane, Bristol BS16 1QY
Date project commenced:	February 2001
Date completion due:	March 2004
Key words:	Biosensor, equipment, instrument, test, food, crop, organophosphate, residues, MRL, pesticide, rapid, detection, analysis

Whilst reports issued under the auspices of the HDC are prepared from the best available information, neither the authors nor the HDC can accept any responsibility for inaccuracy or liability for loss, damage or injury from the application of any concept or procedure discussed.

The contents of this publication are strictly private to the University of the West of England (UWE) in which the IP is invested on behalf of the consortium for LINK project FQS12. No part of this publication may be copied or reproduced in any form or by any means without prior written permission of the UWE.

**LINK - RAPID ANALYTICAL SYSTEMS FOR RAW PRODUCE QUALITY AND
SAFETY ATTRIBUTES (FQS12)**

Final Report

HGCA Project 2278

Contents

ABSTRACT	1
SUMMARY.....	2
INTRODUCTION	2
PROJECT OVERVIEW	5
CONCLUSIONS.....	7
TECHNICAL DETAIL 1 - SELECTION AND STABILIZATION OF ENZYMES.....	8
INTRODUCTION	8
INITIAL STABILIZER SCREENS:.....	8
SELECTION OF DROSOPHILA AChE MUTANTS.	8
STABILIZER SCREENS ON AChE MUTANTS.....	9
STABILIZER SCREENS ON CARBON SQUARES	10
LONG TERM STABILITY OF AChE BASED SENSORS.....	12
CONCLUSIONS.....	13
TECHNICAL DETAIL 2 - RAPID EXTRACTION AND OXIDATION OF ORGANOPHOSPHATE PESTICIDE RESIDUES FROM WHEAT AND APPLES	14
INTRODUCTION	14
MATERIALS.....	14
APPARATUS	15
EXTRACTION VESSEL.....	15
METHODS	16
RESULTS	17
CONCLUSIONS.....	19
REFERENCES	20
TECHNICAL DETAIL 3 - DEVELOPMENT OF BIOSENSORS AND PATTERN RECOGNITION SOFTWARE	21
INTRODUCTION	21
SENSOR ARRAY DESIGN AND FABRICATION	21
ELECTROCHEMICAL CHARACTERISATION.....	23
DATA ANALYSIS AND PATTERN RECOGNITION.....	26
BIOSENSOR OPERATION IN THE PRESENCE OF OXIDISING AGENTS AND METHANOL AND ETHANOL	26
CONCLUSIONS.....	27
TECHNICAL DETAIL 4 - PATTERN RECOGNITION SOFTWARE.....	28

INTRODUCTION	28
PATTERN RECOGNITION SOFTWARE	28
RESULTS	35
DISCUSSION	38
CONCLUSIONS.....	38
REFERENCES	38
TECHNICAL DETAIL 5 – PROTOTYPE INSTRUMENT DEVELOPMENT AND FABRICATION.....	39
INTRODUCTION	39
INSTRUMENT SPECIFICATION	39
SIX ISOLATED POTENTIOSTAT SIGNAL CONDITIONING CIRCUITS.....	41
FLUID HANDLING SYSTEM.....	43
MICROPROCESSOR SYSTEM.....	44
POWER SUPPLY	47
THERMOSTAT HEATER AND CONTROLLER	47
PC INTERFACE.....	47
CASEWORK	48
INITIAL EVALUATION	48
DISCUSSION	48
CONCLUSIONS.....	49
TECHNICAL DETAIL 6 – END-USED EVALUATION OF PESTICIDE BIOSENSOR	50
INTRODUCTION	50
MATERIALS AND METHODS	50
RESULTS	52
DISCUSSION	56
CONCLUSION	57
PUBLICATION ARISING FROM PROJECT	58
POSTER PRESENTATIONS.....	58
FULL REFEREED PAPERS.....	58
CHAPTERS IN BOOKS	59
APPENDIX	60

Abstract

The aim of this three-year project was to investigate scientific and technological issues involved in the implementation of rapid sensor technology, for the detection of organophosphate residues in raw food products. The project finished at the end of January 2004 and succeeded in demonstrating that an array of biosensors can be used to rapidly detect and measure organophosphates in samples of grain.

The project successfully integrated rapid extraction techniques, biosensor technology, instrument design and sophisticated pattern recognition software which resulted in the development of a prototype instrument that could rapidly detect and measure different organophosphate pesticides in grain. The instrument relies on the fact that organophosphate pesticides poison, or inhibit the enzyme acetylcholinesterase. Slight modifications to the active site cause the enzyme to be inhibited to differing extents by a given pesticide. Therefore an array of six enzymes, each slightly different, will give a characteristic pattern of inhibition to each pesticide. A neural network programme recognizes the pattern of inhibition and identifies the pesticide and its concentration. Different pesticides will produce a different pattern of inhibition that can be recognised by the neural network programme.

During the programme of investigation different parts of the analytical system were developed and optimised. This included an extraction method which involved design of an extraction vessel and oxidation method. Development of the biosensor array involved selection, immobilisation and stabilization of enzymes; design, characterisation and optimisation of the electrodes. An instrument was designed and a prototype produced to take the biosensor array. The instrument had a fluidics system to take the pesticide extract to the biosensors and supply enzyme substrate and wash solutions at the appropriate times. The currents generated by the biosensors are read into a neural network programme that had to be trained to recognise particular patterns of inhibition for each pesticide. The final part of the research programme was for an end user to evaluate the complete analytical system which was composed of the extraction process and the analysis by the prototype instrument.

The outcome of the project was to demonstrate that rapid sensor technology can be used to detect and measure organophosphate pesticides residues extracted from raw food products. Measurements made on the prototype instrument were validated by an end-user in an analytical laboratory and the instrument was portable and could be used by semi-skilled personnel. The total assay time was slightly less than 30 minutes although it may be possible to reduce this to approximately 20 minutes. The technology developed could be developed further to measure other substances in food such as toxins or antibiotics.

Summary

Introduction

Pesticides are used in agriculture to control insect pests and there are increasing consumer demands for food and drink of consistent high quality in terms of safety. This concern is reinforced by government legislation that necessitates food processors, wholesalers and retailers to ensure due diligence and traceability of their raw food products. Maximum residue levels (MRLs) for pesticide residues in food are set for consumer safety, also to allow free trade. Food companies ensure that these raw materials are both safe and legal, so surveillance for pesticide residues in foods is an important procedure.

In the production of food a wide range of compounds are used to treat crops that have the potential to leave residues after processing. The possibility of pesticide residues in grain, salads and fruit are of particular public and commercial concern. The end-users of grain provide an excellent model industry for the development of innovative analytical approaches as approximately 7.4 million tonnes goes for human consumption.

Conventional pesticide, determination methods generally involve an organic solvent extraction step, followed by chromatographic analysis. These methods require the use of large quantities of hazardous organic solvents, and specialist and expensive chromatography equipment. They are time-consuming and expensive to perform, and, for these operational reasons, only a small sample of raw materials used in food production is monitored for pesticide residues. Ideally, analytical methods to measure pesticide residue levels in food should be rapid, inexpensive and suitable for use in the earliest stages of the food chain, for example, on farm or at intake for traders and processors. This would then allow food companies to monitor all raw materials for safety and legal compliance. In this project, the innovative analytical approach was the development of an array of biosensors to detect and measure organophosphate pesticide residues.

The principal underpinning the technology developed during this project is that organophosphates will inhibit, or poison, the enzyme acetylcholinesterase. It is this property that has been exploited to develop biosensors that are sensitive to a range of pesticides. The biosensor is fabricated by immobilizing enzyme to an electrode surface where it acts on a substrate to produce an electroactive product which produces a current which is measured; this is shown diagrammatically in figure 1A. If pesticide is present the enzyme becomes inhibited and no product is formed and no current generated (figure 1B). Slightly different forms of acetylcholinesterase will be inhibited by different pesticides to differing extents. This means if an array of biosensors were fabricated, each biosensor having a different form of the enzyme will respond differently to a particular pesticide and the array will have produce a pattern of inhibition for that pesticide. Different pesticides will produce different patterns of inhibition in the biosensor array.

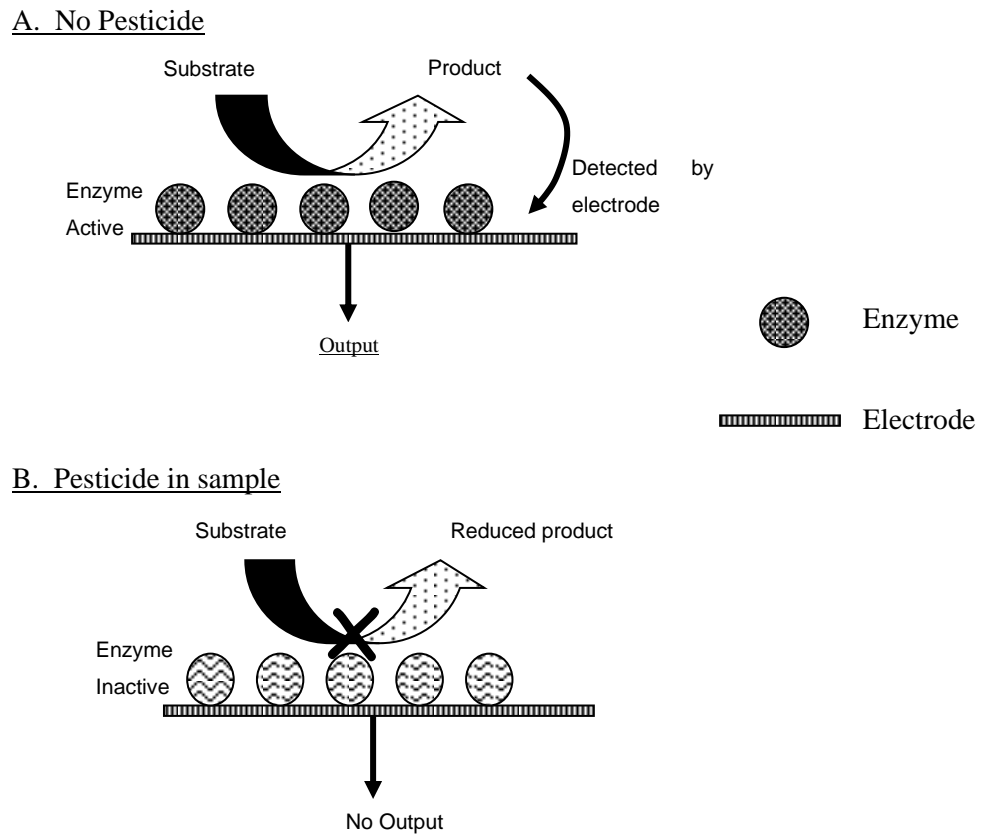

Figure 1. Diagram representing the action of the biosensor. A) In the absence of pesticide the enzyme produces a product which is measured by the electrode producing an output. B) When pesticide is present the enzyme is inactivated and reduced product is formed, consequently there is a reduced output from the electrode.

Sophisticated software can analyse the pattern of inhibition to identify and quantify the pesticide present in the grain sample. Figure 2 shows two different patterns of inhibition, one by omethoate and the other by malaoxon. In order that the pesticide can be presented to the biosensor it first must be extracted from a sample of grain and then introduced into the instrument that holds the biosensors.

The overall aim of this project was to investigate the scientific and technological issues in the implementation and development of rapid, low-cost sensor instrumentation for the measurement of organophosphorus (OP) residues in raw food products, as a model system for the further development and extension to other analytes. The system was designed to be portable for use in in-take laboratories and to be used by semi-skilled operatives.

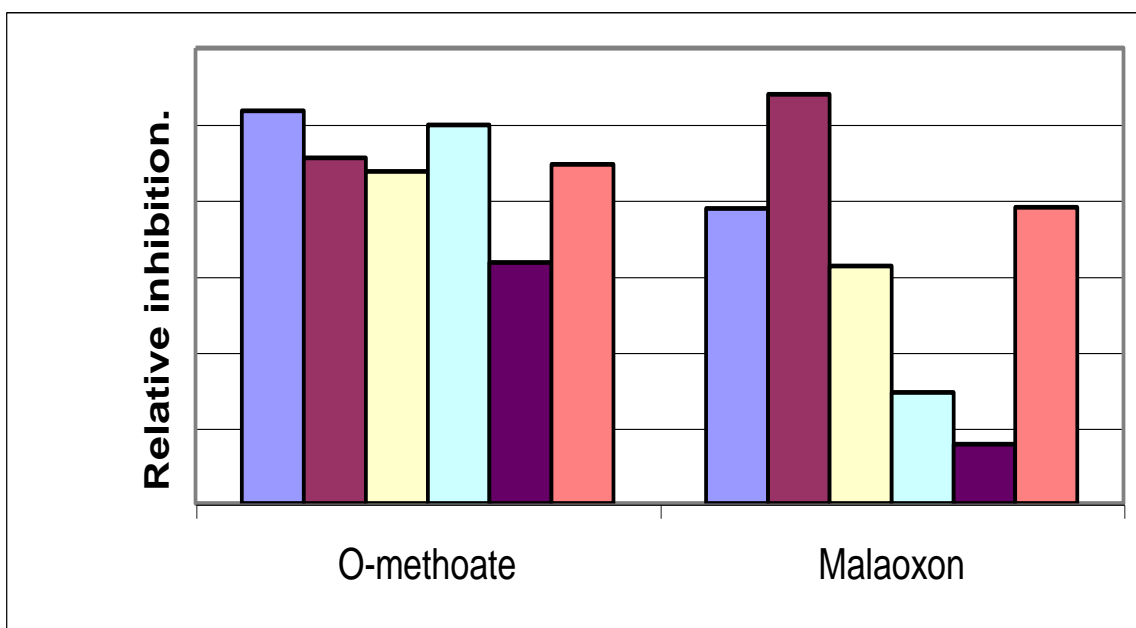

Figure 2. Relative inhibition of an array of six enzyme biosensors for two pesticides; omethoate and malaoxon. Two different patterns of inhibition can be clearly seen.

Project overview

In the development of this new and innovative analytical approach to organophosphate pesticide analysis a number of different technologies were integrated to produce an instrument that underwent evaluation by an end user. The project naturally fell into six main areas: enzyme selection and stability; development of a rapid extraction method; development of biosensors; pattern recognition software; instrument design and fabrication; instrument evaluation by an end-user. Summaries of the work undertaken in these areas are given in the following sections.

Enzyme selection and stabilization

In this part of the project the enzymes to be used on the biosensors were chosen and experiments performed to optimise stabilization reagents in order that a final product would have a long shelf life. Wild-type acetyl cholinesterase and a number of modified enzymes were chosen according to their susceptibility to inhibition by different organophosphate pesticides. It was important that the different enzymes were inhibited to different extents by different pesticides. Six pesticides were initially chosen to evaluate the instrument, these were: chlorpyrifos-ethyl, pirimiphos-methyl, chlorpyrifos-methyl, malathion, dichlorvos and dimethoate.

The enzymes were immobilized on to a carbon surface of an electrode using a glutaraldehyde reaction and stabilised with a mixture of sucrose and dextran sulphate. For simplicity this mixture was used for all enzymes and they were shown to be stable on the electrode surface for at least 50 days stored in the same manner as a commercial product. The outcome from this part of the project was the selected enzymes, were shown to be stable on the working electrodes.

Rapid extraction technique

An extraction vessel was designed and built for the rapid extraction of organophosphate pesticide from samples of grain using the solvent Phytosol. This solvent had the advantages of being inert, non-toxic and evaporates readily. Also a novel, rapid oxidation method was developed in order that the extracted pesticide residues would be in the oxidised form which the biosensor recognised. This part of the project enabled grain samples to be taken and any pesticide to be extracted in approximately ten minutes. The extract was dissolved in a small amount of liquid and introduced in to the instrument of the measurement part of the analysis.

Development of biosensors

This element of the project investigated the electrochemistry of the enzyme reaction and fabrication and optimisation of the biosensor chips. Electrodes were designed and fabricated using carbon ink on which the selected enzymes were bound using a glutaraldehyde immobilisation technique. The selected enzymes were immobilized one enzyme per electrode, so that six electrodes were used to produce an array of six enzymes. A dielectric mask defined the area of the working electrode. Initial studies showed good reproducibility of

the electrodes, better than 5%. The electrochemical methodology developed for use with the instrument was based on chronoamperometry. Operational parameters were optimised with the view to minimise analysis time and to maintain sensitivity. The enzymes act on a substrate, acetylthiocholine chloride, to produce an electroactive product which produces a current measured by the electrode. Pesticide binds to the active site of the enzyme rendering it inactive. Greater concentrations of pesticide in the sample will result in more of the enzyme on the electrode being rendered inactive. Inhibition studies with increasing concentrations of selected pesticides showed that the different enzymes were selectively inhibited as predicted and the degree of inhibition was shown to be dose dependent. The minimum concentration of pesticide that could be detected was in the order of 10^{-9} moles, significantly lower than the current MRLs. The result of this part of the project was that an optimised array of biosensors were produced that could respond to different pesticides at concentrations much less than current MRLs. The enzyme inhibition reaction took approximately three minutes.

Pattern recognition software

Patterns of inhibition produced by the array of biosensors in response to particular pesticides were recognised by neural network software. After considering different approaches to pattern recognition, a particular software package was chosen. The neural network needs to be trained with inhibition data from known pesticides in order that the software can recognise that pesticide in a future sample. As a large number of data points were required to train the network, “artificial” data was generated which allowed noise to be added to the system. The software correctly identified target pesticides with accuracy greater than 95%. The software was only tested with single pesticides as mixtures of two or more pesticides would require much larger amounts of data.

Instrument design and fabrication

An instrument was designed and fabricated to accept a linear array of six electrodes clamped into a temperature controlled Perspex block forming a reaction chambers above the working electrode. The reaction chamber was sealed using an O-ring between the electrode and Perspex block. A fluidic system delivered the sample, enzyme substrate and wash solutions at appropriate times during the measurement cycle. The measurement cycle involved each reaction chamber being filled or washed in turn. A prototype instrument was produced and evaluated by an end user. During the evaluation phase of the project a number of modifications were made to the instrument. At the end of the project a working prototype instrument had been developed that could take extract from the extraction vessel and provide an output to the neural network programme.

Evaluation studies

The final phase of the project brought together all the elements discussed above. The instrument underwent an analytical evaluation and the measurement validated. This confirmed that pesticide in spiked grain could be extracted with good recovery and identified and quantified by the biosensor array at the MRL level.

Conclusions

This project successfully met all the original project objects in that it has been proved that a multi-array biosensor can be used to detect and identify organophosphorus residues to at the current MRLs. This was achieved using a novel, rapid extraction technique in conjunction with modified enzymes that can be used in a biosensor array to produce an inhibition “signature” for different pesticides. The prototype instrument was capable of giving rapid measurement. Further development will be required to produce a commercial that can be used by semi-skilled personnel.

The project brought together academic institutions, instrument and biosensor manufactures, food processors and industry sector partners. The Universities involved were the University of the West of England, Bristol, the University of Leeds and the University of Perpignan, France. Jenway Ltd was the instrument manufacturer and the biosensor manufacturers are Gwent Electronic Materials Ltd. working along side Applied Enzyme Technology Ltd. Food processors involved were Weetabix and RHM Technology. The industry sector partners were the Home Grown Cereals Authority, Horticultural Development Agency and Campden & Chorleywood Food Research Association.

The project co-ordinator was Dr Richard Luxton and lead scientist was Professor John Hart, both at the University of the West of England, Bristol.

Technical detail 1 - Selection and Stabilization of enzymes

Introduction

In this workpackage mutant enzymes were selected depending on their ability to be inhibited by the chosen pesticides. The stability of the enzymes was investigated under a number of different conditions and the best stabilizing agents selected. This will be important in the manufacture of the biosensor in order that the product has a long shelf life.

Objectives:

- To select enzymes for use with selected organophosphate pesticides.
- To select suitable stabilizers for maintaining enzyme activity on the electrode.

Initial stabilizer screens:

Since the drying step is often the point of greatest activity loss, investigations were carried out using readily available wild-type (*Drosophila*) acetylcholinesterase (AChE) in 10 mM Tris pH 8.0, dried down in vacuo onto 96 well microtitre plates. This was done in the presence of a wide range of additives, including polyamine, disaccharides and polysaccharides, and amino acids. Most of these were ineffective or deleterious. However, dextran sulphate (0.1%-0.5% w/v) and sucrose (1% -5% w/v) combinations proved most effective at preventing activity loss on drying and in stabilizing the enzyme against further activity loss for more than 500 days at 37°C. Higher concentrations of sucrose (up to 5%) were most effective at preventing loss on drying, but more difficult to work with due to their increased viscosity and longer time taken to dry the enzyme. Results for the first 100 days are shown in figure 3. The best combination found was 5 % (w/v) sucrose plus 0.1% (w/v) dextran sulphate.

Selection of *Drosophila* AChE mutants.

The selection of mutants for use in the electrode array was made on the basis of available organophosphate inhibition data supplied by Prof. D. Fournier, University of Perpignan. Initially mutants were selected with the highest K_i values for dichlorvos, pyrimiphos oxon, omethoate and malaoxon. These were then cross referenced to identify the 'best discriminators' on the basis of the highest ratios between K_i values for any particular mutant. Enzymes B3, B65, B4-21, B2 and B4 were selected, in addition to wild-type enzyme.

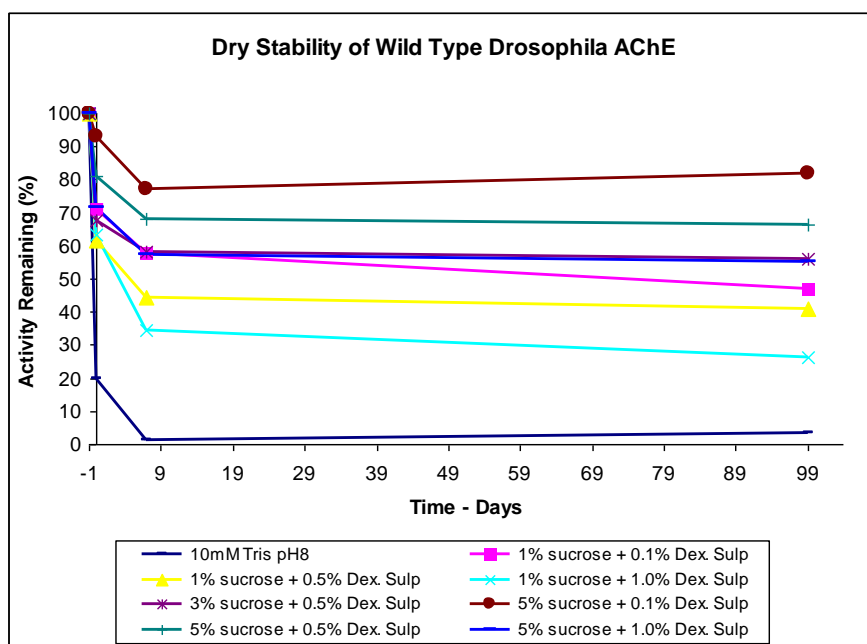

Figure 3. Screen of wild-type Drosophila AChE dried onto 96 well plates in 10 mM Tris, pH 8.0 and sucrose plus dextran sulphate as indicated. After being stored at 37°C for the time indicated AChE activity was measured using 1 mM acetylthiocholine in 50 mM K₂HPO₄ buffer, pH 8.0.

Stabilizer screens on AChE mutants

Plate based screens, as described above, were subsequently mounted for the mutants B3, B65, B4-21, B2 and B4. Typical data are shown in figure 4 for mutant B65 where again 5 % (w/v) sucrose with 0.1 % (w/v) dextran sulphate was an effective stabiliser. Inclusion of 1% (w/v) polygalacturonic acid and 100 mM hydroxyproline were also useful additions in preventing initial activity loss upon drying and preserving activity during storage.

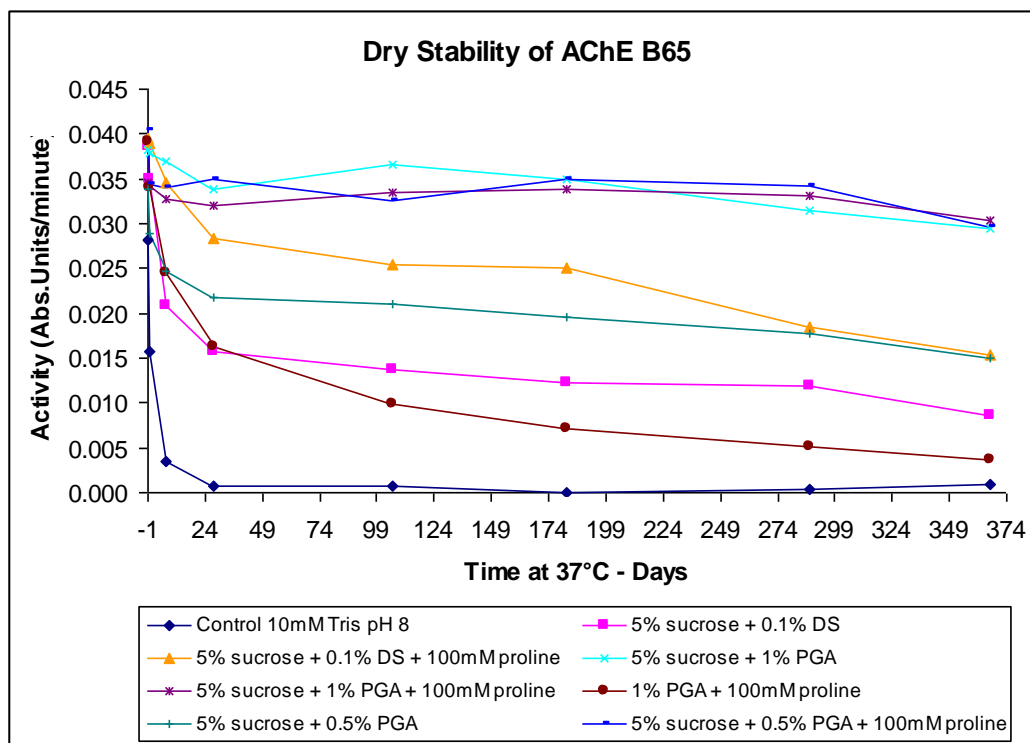

Figure 4. Plate based stabilizer screen of mutant B65. Plate preparation and subsequent assays are as in Figure 3.

Stabilizer screens on carbon squares

The effects of buffer.

Following the plate based assays, wild type AChE was dried down onto 3 mm screen printed carbon squares (these are essentially the same area as the working electrode used on the electrodes of the biosensor), in a range of buffers including 10 mM Tris pH 8.0, 10 mM MOPS pH 7.0, 10 mM HEPES pH 8.0 or 10 mM MES pH 6.0, plus 5 % (w/v) sucrose, 0.1 % (w/v) dextran sulphate and 100 mM hydroxyproline as stabilizers. Best prevention of activity loss on drying and subsequent storage was achieved with MOPS, but the stability achieved was not significantly better than that achieved using Tris and HEPES buffer. Results are shown in figure 5.

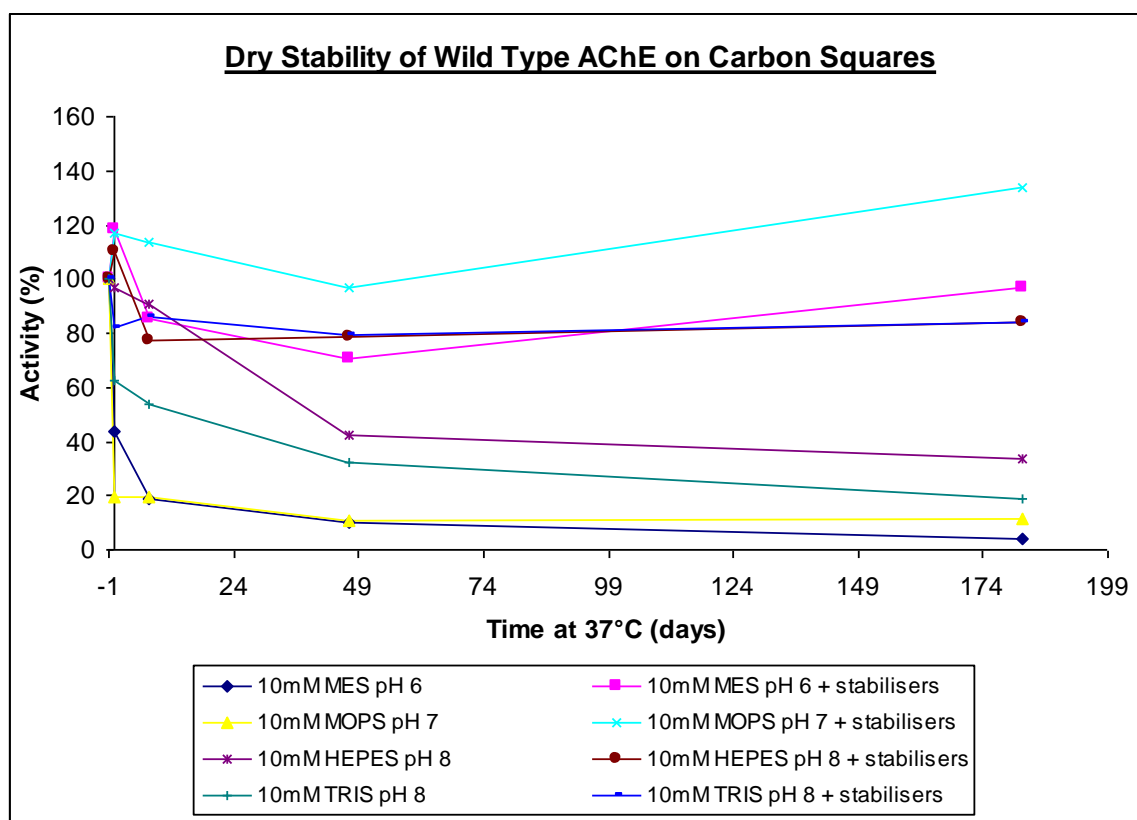

Figure 5. Wild-type AChE was dried down onto 3 mm screen printed carbon squares in the buffers indicated and in the presence of 5 % (w/v) sucrose, 0.1 % (w/v) dextran sulphate and 100 mM hydroxyproline. After being stored at 37°C for the times indicated the AChE activity was measured as in Figure 3.

The selection of optimum stabilizers.

It was clear from screens of the mutant enzymes that in some cases, sucrose/PGA/hydroxyproline rather than dextran sulphate was the best stabilizer (c.f. B3 and B65 in Figure 6.). It should be noted that activity levels were slightly variable and overall the preference for PGA over dextran sulphate was not a strong one. Experiments were also performed in which the AChE was cross-linked to the C-square according to conditions supplied by John Hart at the University of the West of England. Although the data (not shown) was much more variable, the broad conclusions concerning stabilizer selection still applied.

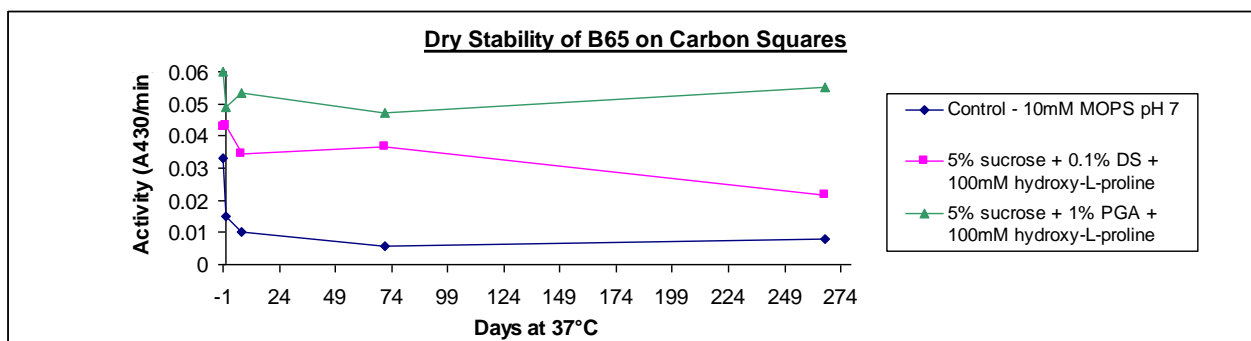
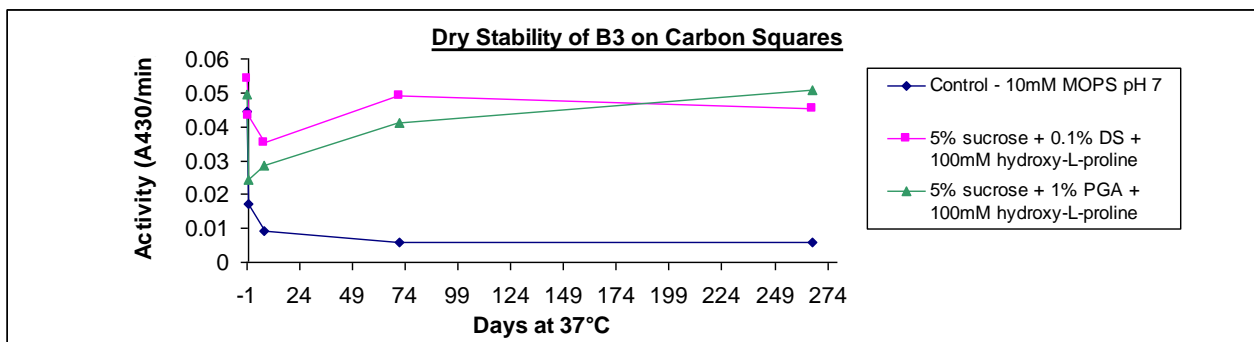

Figure 6. Mutant AChEs were dried onto 3 mm screen printed C squares in 10 mM MOPS, pH 7 and with stabilizers indicated. After storage at 37°C AChE activity was assayed as described in Figure 3.

Long term stability of AChE based sensors

Following the various stabilizer screens, stability tests on complete sensors are complete for this project. For academic interest, some stability studies will be continued. Due to difficulties in producing sensors with mutants B2 and B3, only data for mutants B65, B4-21, and B4, and wild-type (B1) are shown in figure 7. There is considerable variation in AChE activity on the final sensors after drying with stabilizers present. However, all show good retention of starting activity, at last measurement up to 45-50d as seen in Figure 7.

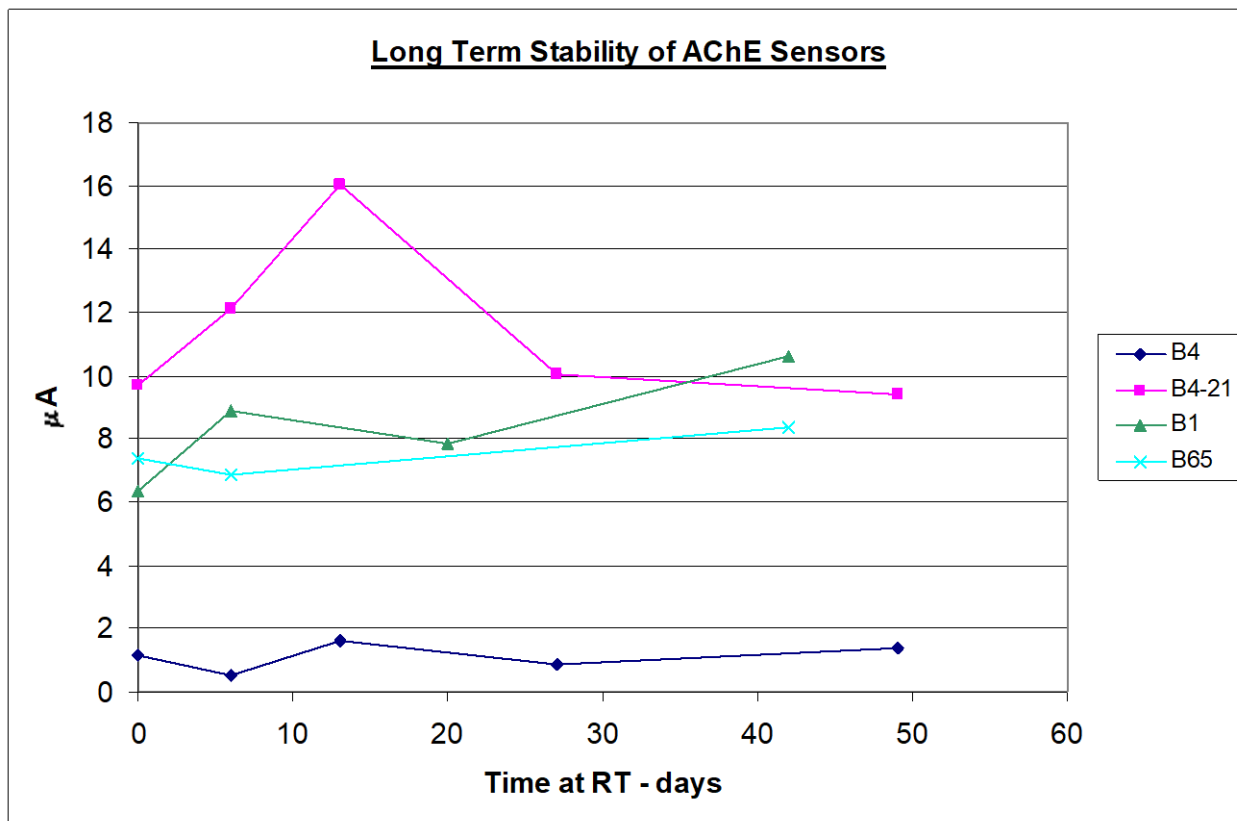

Figure 7. Sensor chips were prepared as described by the Hart laboratory using 0.09 U AChE per chip, and were dried in the presence of 5 % (w/v) sucrose and 0.1 % (w/v) dextran sulphate and 50 mM Na₂HPO₄ pH 8.0. After storage, desiccated at room temperature, activity was measured electro-chemically in the same buffer using 1 mM acetylthiocholine.

Conclusions

The stabilizer selected for use on the electrodes was 5 % (w/v) sucrose and 0.1 % (w/v) dextran sulphate and 50 mM Na₂HPO₄ buffer pH 8.0.

Technical detail 2 - Rapid extraction and oxidation of organophosphate pesticide residues from wheat and apples

Introduction

In this workpackage a rapid organophosphate (OP) pesticide extraction method was developed for determining six selected OP pesticides in fruit and cereals. Analytes were extracted into a refrigerant gas and the residues oxidised to their oxon metabolites to ensure full compatibility with the biosensor array on the instrument.

The increasing consumer demand for safe food and drink is accompanied by the need for novel rapid analytical techniques capable of screening food ingredients and products for the presence of pesticide residues. In order to achieve the project objective of researching a rapid multi-array disposable biosensor capable of identifying and quantifying a pre-selected suite of organophosphorus pesticide residues it was essential to initially develop a rapid, safe and reliable quantitative pesticide residue extraction technique. To ensure full compatibility with the biosensor, and hence attain maximum sensitivity, it was essential that any phosphorothioate (P=S) compounds were oxidised to their respective oxygen analogues. This was a critical step because phosphorothioates are not effective inhibitors of acetylcholinesterase.

Six pesticides were selected by CCFRA based on usage, chemical toxicity, occurrence of residues and frequency they exceeded maximum residue level (MRL). The six selected OP pesticides were: chlorpyrifos, chlorpyrifos methyl, dichlorvos, dimethoate, malathion, and pirimiphos methyl.

Objectives:

- Validation of a rapid extraction system.

Materials

Extraction materials

(a) Acetone, methanol. -Fisher

(b) Phytosol D (Composition: 1,1,1,2-Tetrafluoroethane >88%, Dimethyl ether >9%). Advanced Phytonics Ltd.

(c) Hydromatrix.-Varian

(d) Pesticide standards. - Qmx. 100 mg/L stock solutions of dichlorvos, chlorpyrifos, chlorpyrifos methyl, dimethoate, malathion, malaoxon and pirimiphos methyl were prepared in methanol. Mixed working standard solutions were prepared to fortify samples at the required concentrations. Mixed calibration standards were prepared for GC quantification. All standards were stable for up to 6 months stored refrigerated

Oxidation reagents

Sodium hypochlorite solution (14%) BDH diluted to 1% in distilled water.

Phosphate buffered saline –PBS (Dulbecco A) Oxoid. One tablet dissolved in 100ml of distilled water (pH 7.4).

Mixed OP pesticides 10 mg/l solution prepared in methanol. Standards were stored refrigerated for up to 6 months.

Apparatus

GC Systems

Hewlett Packard 5890 with flame photometric detector (GC/FPD)

Column: DB5 30M*0.53mm

Temperature Program: 100°C - 215°C @ 5°C/min, 215°C - 325°C @ 40°C/min

Injector Temperature: 200°C

Detector Temperature: 300°C

Carrier Gas: Helium 40 psi

Varian 3800 Gas chromatograph with Saturn 2000 Ion trap detector (GC/MS)

Column: DB5 30M*0.25mm

Temperature Program: 2min@ 80°C. 80°C -210°C @ 5°C/min, 210°C - 360°C @ 70°C/min

Injector Temperature: 260°C

Transfer Line: 280°C

Carrier Gas: Helium @ 1ml/min

Scan Range-60-400 m/z

Extraction Vessel

A gas tight extraction vessel was designed by CCFRA and engineered by Jenway.

Extractions were performed in a 130 ml glass extraction vessel vertically enclosed within a Perspex safety cylinder; a drawing of this can be seen in the appendix. The end of the glass extraction tube was sealed with an aerosol cap fitting to allow the input of gaseous Phytosol extraction solvent, and to allow the release of extracted analytes. The collection vial was placed in a beaker containing water at 40°C (+/-2 °C).

Methods

Samples were homogenised prior to extraction.

Extraction Procedure

Fruit and vegetables:

5g (+/-0.5g) of homogenised sample and 5 g of hydromatrix (+/-0.5g) were weighed (to 2 decimal places) into a beaker, mixed thoroughly with a glass stirring rod, and transferred to the extraction vessel. The vessel was sealed, Phytosol added via the aerosol closure to approximately 1 cm above the level of sample/hydromatrix mixture, and the vessel shaken for at least 1 minute. The solvent was aspirated through silicon tubing into a collection tube placed in a beaker containing water at 40°C (+/-2°C). The Phytosol extraction was repeated and the solvent transferred to the collection tube.

The combined extracts were allowed to evaporate to dryness and the residue redissolved and made up to the relevant volume in methanol. (Acetone was the solvent of choice for the gas chromatographic determination of fortified samples).

Quantification was carried out by gas chromatography with flame photometric detection.

Cereals:

As the above fruit and vegetable procedure except 1ml of methanol added prior to Phytosol extraction.

Oxidation Procedure

1 ml of 10 mg/l mixed OP pesticide standard solution and 6ml PBS solution were pipetted into a 10ml test tube and mixed thoroughly. 1% sodium hypochlorite solution was added, the solution mixed and then incubated for 5 minutes at 40°C. After incubation 1ml of ethanol was added to neutralise the reaction. (The parent OP's and reactants were extracted into iso-octane for analysis by gas chromatography with mass spectrometric detection to determine the extent of oxidation).

Results

Apple and milled wheat samples were fortified with OP pesticides at a level of 1 mg/kg and extracted using the Phytosol extraction procedure. Each sample was fortified with the six chosen OP pesticides and malaoxon (the maximum residue level for malathion is the sum of parent and oxon compounds).

The recoveries of the fortified samples are shown in Tables 1 and 2.

Analyte	Mean % Recovery	Std Dev	% RSD
Chlorpyrifos	84	4.9	5.9
Chlorpyrifos Methyl	80	7.3	9.1
Dichlorvos	70	3.5	5
Dimethoate	97	6.1	6.3
Malaoxon	103	8.3	8.1
Malathion	100	6.4	6.4
Pirimiphos Methyl	91	3.6	4

Table 1. Mean recoveries obtained by Phytosol extraction of a 1mg/kg spiked apple sample (Mean of 5 replicates)

Analyte	Mean % Recovery	Std Dev	% RSD
Chlorpyrifos	93	11.1	11.9
Chlorpyrifos Methyl	101	8.6	8.5
Dichlorvos	82	9.7	11.8
Dimethoate	88	7.7	8.7
Malaoxon	92	12.1	13.1
Malathion	103	10.8	10.5
Pirimiphos Methyl	94	10.4	11

Table 2. Mean recoveries obtained by Phytosol extraction of a 1 mg/kg spiked milled wheat sample (Mean of 5 replicates)

The oxidation procedure was optimised to determine the most effective concentration of oxidising reagents. The degree of oxidation of the parent phosphorothioate compounds was determined using a Varian Saturn 2000 GC/MS. The oxidation products were identified using standard reference materials and by comparison against mass spectral data (WILEY 275 mass spectral library).

Dichlorvos differs from the other five elected OP compounds in that it does not require oxidation (it already contains the P=O bond and therefore is a good inhibitor of acetylcholinesterase). However, it was also subjected to the oxidation procedure to ensure that there was no loss of dichlorvos or production of any oxidation metabolites.

The extent to which parent OP's were oxidised to their corresponding oxon analogues is expressed as a percentage of initial parent concentration. The relative conversions of parent OP compounds to their respective oxons are shown in table 3.

These results indicate that 0.1ml is the optimal volume of 1% sodium hypochlorite that should be used in the oxidation assay. This corresponds to a final concentration of 0.01% sodium hypochlorite.

Dimethoate was not oxidised to its respective oxon.

OP Compound	Volume of 1% NaOCl (ml)	% Conversion to oxon
Dichlorvos	0.05	0%- Parent compound intact
	0.10	0%- Parent compound intact
	0.20	0%- Parent compound intact
	0.50	0%- Parent compound intact
Chlorpyrifos	0.05	28%
	0.10	60%
	0.20	99%
	0.50	99%
Chlorpyrifos Methyl	0.05	4%
	0.10	17%
	0.20	37%
	0.50	34%
Pirimiphos Methyl	0.05	15%
	0.10	54%
	0.20	Total parent and oxon degradation
	0.50	Total parent and oxon degradation
Malathion	0.05	<1%
	0.10	7%
	0.20	5%
	0.50	5%
Dimethoate	0.05	Total parent and oxon degradation
	0.10	Total parent and oxon degradation
	0.20	Total parent and oxon degradation
	0.50	Total parent and oxon degradation

Table 3. Percentage conversion of parent OP's to their respective oxon analogues (Incubated for 5 minutes at 40°C)

Conclusions

All of the selected pesticides were successfully extracted from the fortified wheat and apple samples. The extraction step is simple to perform, relatively inexpensive, uses only a minimal amount of non-chlorinated solvent and allows up to six samples to be extracted in one hour. Further work at CCFRA has successfully shown that this technique can be extended to the extraction of additional OP pesticides and also to the extraction of further groups of pesticide compounds such as the organochlorines and carbamates.

To attain full inhibitory status, organophosphate compounds with a P=S bond (organophosphorothioates) must undergo an oxidative desulphuration reaction to convert them to their oxygen analogues (P=O).

Oxidation by sodium hypochlorite solution was identified as being the most effective technique. The optimal concentration of sodium hypochlorite was determined to be 0.01%. At this level the structure of dichlorvos remained intact. The conversion of only a small percentage of organophosphorothioate to its oxon derivative is likely to significantly increase its inhibition of acetylcholinesterase. Therefore although the conversion of malathion to malaaxon was only relatively small (7%) this is likely to result in a marked improvement in biosensor response. At concentrations greater than 0.01% pirimiphos methyl undergoes further oxidation and subsequently is not oxidised to its respective oxon metabolite. If the concentration of sodium hypochlorite were to be increased, additional amounts of ethanol would be required to neutralise the reaction. The consequence of increasing either the concentration of sodium hypochlorite or ethanol would result in a reduction of enzyme activity (1) and hence a reduction in sensitivity of OP pesticide residues.

Overall, several benefits of the gaseous extraction procedure are worth noting. The technique allows the rapid extraction of pesticides from a range of raw food products in a highly cost effective (typical consumable cost for each assay is £4) and efficient manner. The use of a gaseous solvent avoids the need for any costly laboratory apparatus for sample extraction and concentration. It is possible that a series of extraction cells could be developed to enable multiple samples to be extracted simultaneously, making it a viable technique for a pesticide residue contract laboratory.

References

1. Twomey S. The study and optimisation of the enzyme inhibition bioassay 96 for the detection of organophosphate and carbamate compounds. University of Nevada. 2002

Technical detail 3 - Development of biosensors and pattern recognition software

Introduction

This workpackage developed the electrochemical method to measure the activity of the enzyme on the electrode, forming the biosensor. Initial experiments evaluated the sensor design, fabrication and reproducibility. Inhibition of enzyme activity was evaluated for the different pesticides and the shown to be dose dependent. Different pesticides were shown to inhibit the different enzymes to different extents allowing an array of sensors to be fabricated that show particular patterns of inhibition characteristic of a particular pesticide.

Objectives:

- To design, characterise and optimise the biosensor array
- Validate the electrochemical measurement.
- To demonstrate enzyme inhibition with pesticide
- To demonstrate differential inhibition of enzymes with different pesticides

Sensor Array Design and Fabrication

Design

The amperometric biosensor arrays were based on two screen-printed electrodes deposited side by side onto a PVC substrate. The working electrode contained 5% (m/m) CoPC as the electrocatalyst in a carbon ink (C10903D14) developed by UWE and Gwent Electronic Materials (GEM). An Ag/AgCl electrode served as a reference/counter electrode and a dielectric layer was printed over the two electrodes to define their areas as shown in Figure 8.

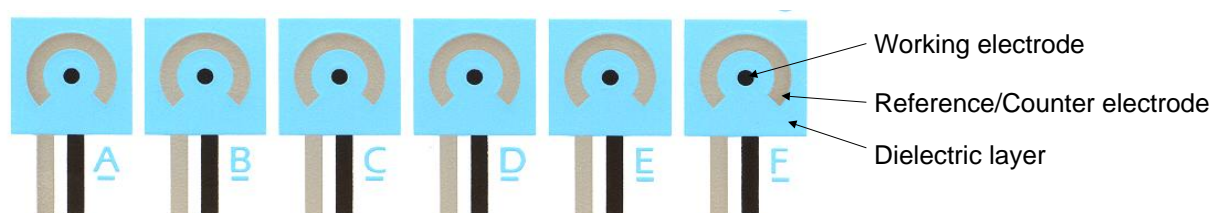

Figure 8: Diagram of a screen-printed sensor array.

The principle of operation of the biosensors is illustrated in figure 9. The AChE enzyme stabilised on the surface of the working electrode converts the substrate acetylthiocholine to thiocholine, which then undergoes electrocatalytic oxidation at the CoPC-SPCE. This occurs by the thiol reducing Co^{2+} to Co^+ , which can then be re-oxidised back to Co^{2+} at a potential of 0V vs. Ag/AgCl. The current generated during the re-oxidation step constitutes the analytical response. In the presence of an OP, AChE is inhibited leading to a decrease in thiocholine production and a corresponding decrease in anodic current. This decrease is proportional to the logarithm of the OP concentration.

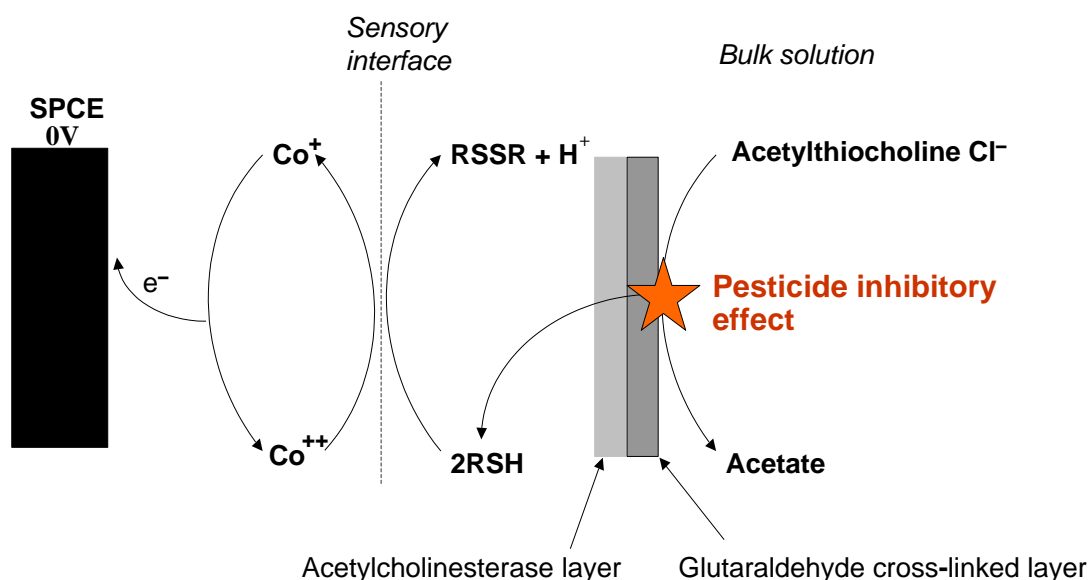

Figure 9: Schematic diagram showing various reactions taking place during proposed amperometric assay.

Fabrication and Modification

The fabrication of the biosensors at each stage of the project followed the protocol developed by UWE. To convert these Screen-printed carbon electrodes (SPCEs) into biosensors a fixed concentration of the *D. melanogaster* wildtype or one of the mutant AChE enzymes was dried onto the surface of the working electrode in a vacuum at 4°C. The five mutant enzymes included in this study were B02, B03, B04, B65 and B421 (Universite Paul Sabatier, Toulouse, France). The enzyme was immobilized onto the SPCE using glutaraldehyde (Sigma, Gillingham, UK) by drying in a vacuum at 4°C.

Electrochemical Characterisation

Non-Enzyme Array Reproducibility

Each batch of screen-printed carbon electrodes was evaluated using two quality control tests at UWE before they were used as biosensors. Cyclic voltammetry with degassed 5mM thiocholine chloride and chronoamperometry with 5mM thiocholine chloride was used to evaluate the reproducibility of the electrodes. The aim was to achieve electrodes with a coefficient of variation below 5% in all tests.

Single Enzyme Array Reproducibility

Precision of the biosensors fabricated using the procedure outlined above using one of the six AChE enzymes was determined by electrochemical measurements in conjunction with chronoamperometry with the control solution (0.5mM acetylthiocholine chloride in 0.05M phosphate buffer pH8.0). The precision of each biosensor type was within the range of 5.1% (B421) to 10.9% (B65).

Multi-Enzyme Array Calibration

Figure 10 shows typical chronoamperograms obtained with a screen printed biosensor fabricated with type B02 AChE following incubation with different concentrations of pirimiphos-methyl-oxon. For this OP biosensor it is clear that the pesticide produces readily measurable differences in response over the concentration range $1 \times 10^{-6} \text{ mol dm}^{-3}$ to $1 \times 10^{-8} \text{ mol dm}^{-3}$ forming a log-linear calibration. It should be added that different magnitudes of inhibition were observed for the five different OPs studied using this biosensor.

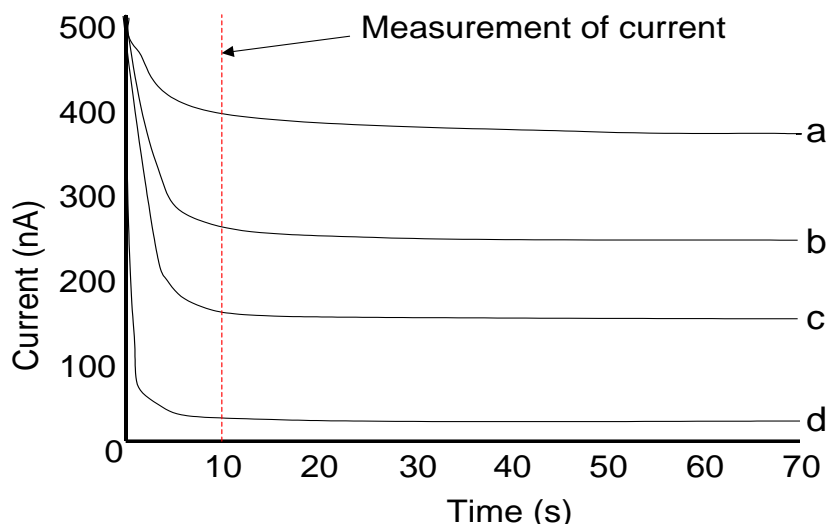

Figure 10: Typical chronoamperograms obtained with a screen-printed OP biosensor (Type B02) after incubation with different concentrations of pirimiphos-methyl-oxon: a) 0 mol dm^{-3} ; b) $10^{-8} \text{ mol dm}^{-3}$; c) $10^{-7} \text{ mol dm}^{-3}$; d) $10^{-6} \text{ mol dm}^{-3}$.

The inhibition behaviour of the six AChE biosensors (types WT, B02, B03, B04, B421 and B65) to the OPs under investigation is summarised in Figure 11. The current responses have been normalised to allow comparisons to be made. Normalisation was performed by relating currents after inhibition to the current obtained for the biosensor in the absence of the pesticide. In general, the OPs examined showed different response patterns at the six-biosensor array, which allows the identification of this group of pesticides when present in food extracts. The development of the neural network programme by Jenway was required to allow the identification step to be automated. In addition, the sensitivity achieved by the array for the OPs studied indicates the possibility of quantifying these species at concentrations below the maximum residual levels (MRLs).

Protocols for assessing and using the biosensors were supplied by UWE to GEM/AET, Weetabix Ltd. and Jenway. Assistance has been given where required in terms of training, analyses and in the interpretation of data.

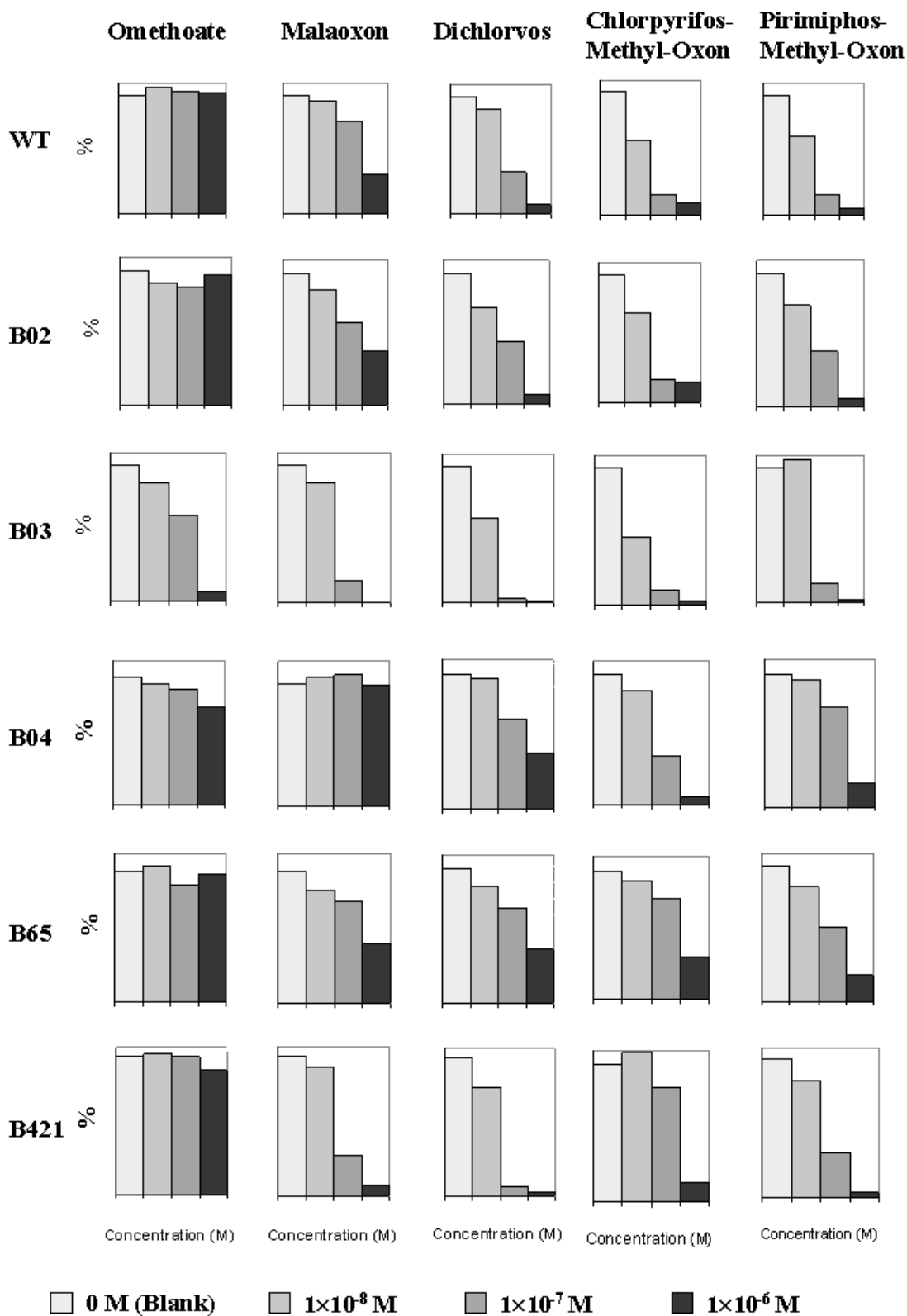

Figure 11: Normalised responses for five OPs with an array of six amperometric biosensors.

Data Analysis and Pattern Recognition

The data from the array of calibrations of each of the AChE enzymes to the OPs was provided by UWE to Mr Carl Warren at Jenway for the training of the neural network.

Biosensor Operation in the Presence of Oxidising Agents and Methanol and Ethanol

The oxidation of pesticides required an oxidation solution containing ethanol and sodium hypochlorite in phosphate buffered saline (PBS) at pH7. The oxidising solution was evaluated as a whole and as the individual constituents for their affect on the AChE based biosensors. The oxidising solution reduced the activity of the enzyme significantly, however, in isolation it was possible to separate the inhibition effects and evaluate them.

The presence of sodium hypochlorite in the oxidising solution was evaluated for its effect on AChE. Sodium hypochlorite was tested at concentrations up to the maximum possible concentration of 0.0124%. Inhibition of the enzyme occurred at concentrations above 0.006% and increased with concentration. A simple dilution step of the food extract and oxidising solution with a 1:1 dilution before the solutions are in contact with the biosensor surface would remove the inhibition.

The combined methanol and ethanol concentration inhibited AChE at the concentrations required in dissolving the extract and oxidising the solution. When the biosensors were presented with the methanol and ethanol in the presence of extracts the inhibition was significantly reduces. Figure 12 shows the chronoamperometric responses of the biosensor based on WT AChE following incubation in the presence or absence of wheat extract dissolved in methanol.

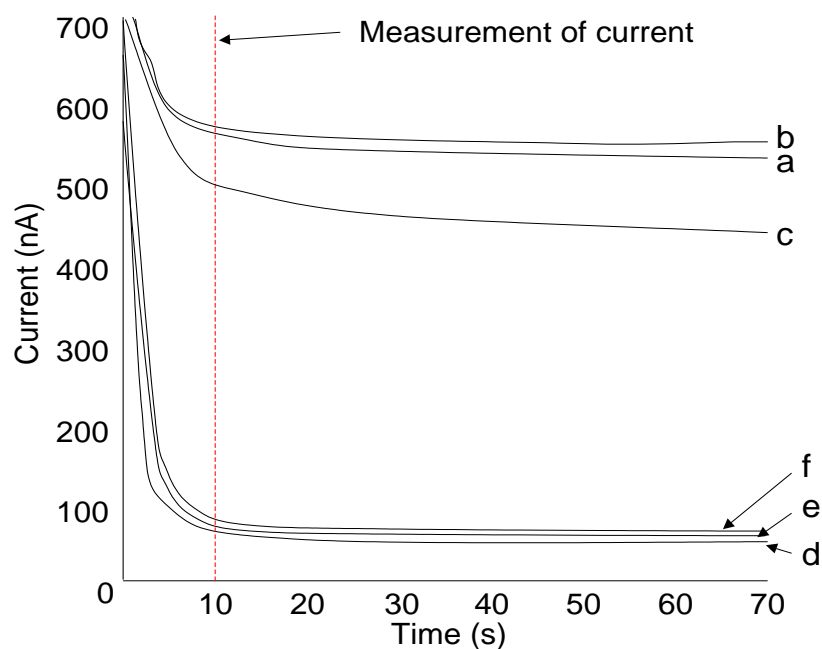

Figure 12: Chronoamperogram obtained with a screen-printed OP Biosensor (Type WT) after incubation with methanol and wheat extract dissolved in methanol in the presence or absence of dichlorvos: a) Blank solution; b) extract in 12% methanol; c) 12% methanol; d) $10^{-6} \text{ mol dm}^{-3}$ dichlorvos; e) $10^{-6} \text{ mol dm}^{-3}$ dichlorvos in 12% extract; f) $10^{-6} \text{ mol dm}^{-3}$ dichlorvos in 12% methanol.

There was no detrimental effect on the biosensor response caused by naturally occurring substances contained within the wheat extract tested. Indeed, the results indicated that the presence of wheat extract prevents loss of enzyme activity when exposed to methanol only. This phenomenon allows the biosensors to potentially be used as part of a rapid solvent-based extraction and analysis system without the need for further sample preparation. It should be noted that the results obtained with extracts from apples were essentially the same as those obtained with wheat extracts.

Conclusions

A suitable electrochemical method was developed to measure the activity of enzymes immobilized on the electrode surface. Pesticides were shown to inhibit enzymes in a dose dependent manner and differential inhibition was achieved with different pesticides. This proved the concept that a biosensor array could be used to detect and measure different pesticides extracted from a grain.

Technical detail 4 - Pattern Recognition software

Introduction

The project required the use of neural network pattern recognition software to determine the composition of an unknown sample. The analyser consists of a six-sensor array, each of which is sensitive to one or more of the six organophosphate pesticides that are being analysed. This section describes the identification of the most appropriate pattern recognition algorithm and the subsequent development of a trial system that has been evaluated using simulated sensor array outputs. Determination of the composition of an unknown sample has been separated into two stages: identification of the pesticide type (using neural network software) and the subsequent quantification of the pesticide level (not based on neural network analysis)

Objectives:

- To identify a suitable pattern recognition software
- To train and evaluate the pattern recognition software

Pattern recognition software

There are many examples of pattern recognition using neural network software. The two most commonly described uses are in optical recognition systems (such as bank note identification) and business analysis systems. These are not directly applicable to this project, but the demand created by these applications has seen the significant advancements in PC based software packages for creating neural network processes. The task was therefore to identify the best software package to use in terms of performance and ease of use.

The field of research most closely associated with the pattern recognition problem for pesticide analysis is the development of the artificial nose. In 1993 Battlemore institute developed a simple electronic nose system; the electronic nose combining a sensor array, pattern recognition software, other instrumentation including a sampling systems, mixing fan, data acquisition system, electronics and cleaning mechanism. The idea of the prototype was to test pattern recognition techniques for implementation in mobile electronic nose systems.

The two algorithms used primarily were back-propagation-trained feed-forward and also a fuzzy ARTmap algorithm. Following a discussion with Professor Gary Montague of Newcastle University, it became clear that it would be necessary to try many different routes to optimise the pattern recognition system.













He recommended a commonly used platform for neural network development, which is the Matlab software suite. This was investigated, but was not considered well suited to this project because of the high mathematical knowledge required for algorithm development. Matlab is certainly well suited to development

from first principles, but this project required a package that was easier to use and which would run a variety of established algorithms on simulated data.

One package looked at was a free-to-use neural network engine called JOONE (Java Object Orientated Neural Engine). This was tried with simple pattern recognition examples (such as the exclusive OR function), but was found to be extremely slow to process training data for anything other than the simplest problem.

Materials and Methods

The software package ultimately chosen was Neuro-Solutions version 4.2 supplied by Neuro Dimension. Their neural network software products are considered among the most powerful and flexible on the market today, but have an intuitive graphical user interfaces that makes them easy to use. The functions available with this package are shown below.

Icon	Name	Description	Primary Usage
	Axon	Layer of PE's (processing elements) with identity transfer function.	Can act as a placeholder for the File component at the input layer, or as a linear output layer.
	TanhAxon	Layer of PE's with hyperbolic transfer function (output range -1 to 1).	Used as hidden or output layer.
	FullSynapse	Full matrix multiplication.	Connects two axon layers.
	L2Criterion	Square error criterion.	Computes the error between the output and desired signal, and passes it to the backpropagation network.
	BackAxon	Layer of PE's with identity transfer function.	Attaches to "dual" forward Axon, for use in backpropagation network.
	BackTanhAxon	Layer of PE's with transfer function that is the derivative of the TanhAxon.	Attaches to "dual" forward TanhAxon, for use in backpropagation network.
	BackFullSynapse	Back full matrix multiplication.	Attaches to "dual" forward FullSynapse, for use in backpropagation network.
	BackCriteriaControl	Input to backpropagation network.	Attaches to Criterion, for use in backpropagation network. Receives error from Criterion.
	Momentum	Gradient search with momentum.	Updates weights. Momentum increases effective learning rate when weight change is consistently in the same direction.
	StaticControl	Static forward controller	Controls the forward activation phase of network.
	BackStaticControl	Static backpropagation controller	Controls the backward activation phase of network (backpropagation).
	File	File input	For network input and desired data from a file.
	ThresholdTransmitter	Thresholded transmitter	For controlling one component based on the values of another.
	BarChart	Bar chart probe	Displays data bar graph style.
	DataGraph	Graphing probe	Displays data versus time.
	MatrixViewer	Numerical probe	Displays numerical values at the current instant in time.
	DataWriter	Numerical probe	Displays numerical values across time. Also allows for the saving of data to a file.

A multilayer perceptrons (MLPs) layered feed-forward network typically trained with static back-propagation was suggested as the most applicable configuration for this type application by the Neuro Dimension support documentation. These networks have found their way into countless applications requiring static pattern classification. Their main advantage is that they are easy to use, and that they can approximate any input/output map. The key disadvantages are that they train slowly, and require lots of training data (typically three times more training samples than network weights).

The actual neural network used is shown below.

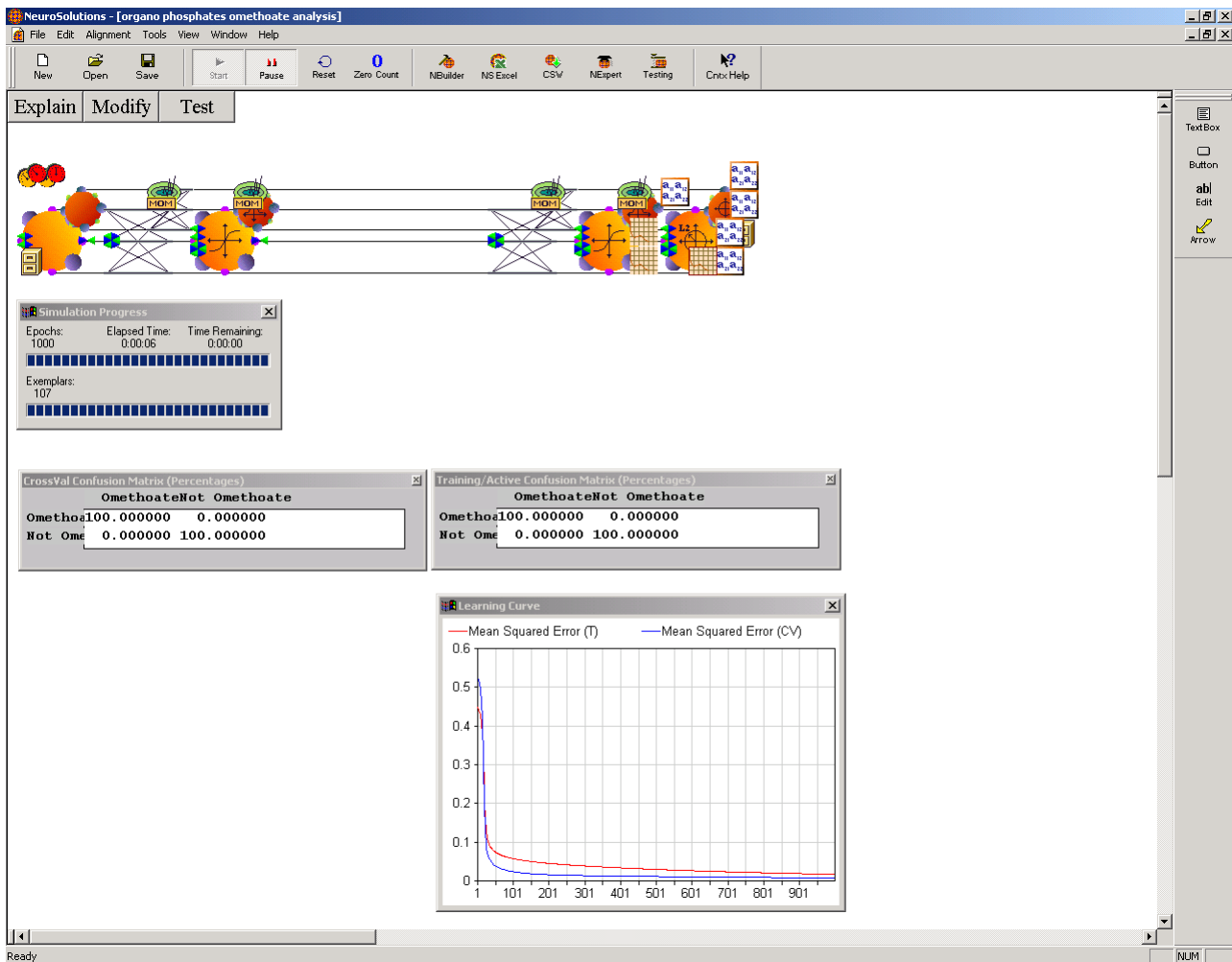

The software also provides an indication of learning success from the training data. As illustrated above, this tends to zero when the training has been successful.

Following the advice of Professor Gary Montague, one of the key areas for investigation was generation of training data. Because of the limited amount of data available and low likely hood that significant amounts of

training data could be supplied, it was necessary to devise a way of extending the data points from the limited data available.

The data that was available was supplied by John Hart of the University of West England and is shown below.

Summary of Mutant AChE Biosensor Calibrations									
Correct to 12/05/2003									
i @ 10s (nA)									
WT					B04				
OP Pesticide	Concentration (M)				OP Pesticide	Concentration (M)			
	0.00E+00	1.00E-08	1.00E-07	1.00E-06		0.00E+00	1.00E-08	1.00E-07	1.00E-06
Omethoate	770	825	797	787	Omethoate	120	113	109	92
Malaoxon	865	828	673	283	Malaoxon	148	156	159	146
Dichlorvos	813	725	289	68	Dichlorvos	104	101	70	43
Chlorpyrifos-Methyl-Oxon	767	744	678	788	Chlorpyrifos-Methyl-Oxon	164	168	167	191
Pirimiphos-Methyl-Oxon	683	454	124	48	Pirimiphos-Methyl-Oxon	144	137	109	26
B02					B421				
OP Pesticide	Concentration (M)				OP Pesticide	Concentration (M)			
	0.00E+00	1.00E-08	1.00E-07	1.00E-06		0.00E+00	1.00E-08	1.00E-07	1.00E-06
Omethoate	362	329	316	349	Omethoate	938	950	935	845
Malaoxon	428	372	268	175	Malaoxon	938	860	275	70
Dichlorvos	471	348	226	35	Dichlorvos	938	730	63	23
Chlorpyrifos-Methyl-Oxon	343	322	266	282	Chlorpyrifos-Methyl-Oxon	938	920	865	825
Pirimiphos-Methyl-Oxon	360	274	152	23	Pirimiphos-Methyl-Oxon	837	705	273	31
B03					B65				
OP Pesticide	Concentration (M)				OP Pesticide	Concentration (M)			
	0.00E+00	1.00E-08	1.00E-07	1.00E-06		0.00E+00	1.00E-08	1.00E-07	1.00E-06
Omethoate	257	225	163	17	Omethoate	150	157	134	146
Malaoxon	257	224	40	0	Malaoxon	150	129	117	69
Dichlorvos	257	160	8	3	Dichlorvos	255	222	182	102
Chlorpyrifos-Methyl-Oxon	257	317	348	328	Chlorpyrifos-Methyl-Oxon	150	143	83	140
Pirimiphos-Methyl-Oxon	110	117	16	2	Pirimiphos-Methyl-Oxon	170	144	93	32

A similar layout was used for the simulated data. It was decided that the training data would be based on a log-linear relationship between sensor output (nA of current) and pesticide concentration. A random value (10% of the calculated value) was added to the basic data to simulate the effects of noise and experimental uncertainty. An additional point was also calculated to allow an “unknown” to be used for testing the pattern recognition system and was not used for generating training data. The relationships chosen looked to mirror the actual responses seen, such that some inputs produced a significant drop in current, while other showed virtually no change in current. Selecting various slope figures to apply and start values (current with no pesticide present) that were similar to the ones measured experimentally simulated this. The original data did contain some anomalies, for example different pesticide concentrations producing similar currents. These were not included in the simulated data. The basic input data used is shown below.

Simulated Test Data For Neural Net Training

06/10/03

i @ 10s (nA)

Random Weight 10.00%

WT

OP Pesticide	UNKNOWN				
	Concentration (M)				
	0.00E+00	1.00E-08	1.00E-07	5.00E-07	1.00E-06
Omethoate	838	837	828	788	738
Malaoxon	863	861	843	763	663
Dichlorvos	868	865	838	718	568
Chlorpyrifos-Methyl-Oxon	825	821	785	625	425
Pirimiphos-Methyl-Oxon	870	865	820	620	370

B02

OP Pesticide	UNKNOWN				
	Concentration (M)				
	0.00E+00	1.00E-08	1.00E-07	4.00E-07	1.00E-06
Omethoate	723	723	722	719	713
Malaoxon	719	717	699	639	519
Dichlorvos	734	734	731	722	704
Chlorpyrifos-Methyl-Oxon	702	701	698	686	662
Pirimiphos-Methyl-Oxon	713	713	708	693	663

B03

OP Pesticide	UNKNOWN				
	Concentration (M)				
	0.00E+00	1.00E-08	1.00E-07	3.00E-07	1.00E-06
Omethoate	807	802	757	607	307
Malaoxon	874	870	834	714	474
Dichlorvos	814	814	813	810	804
Chlorpyrifos-Methyl-Oxon	802	802	801	798	792
Pirimiphos-Methyl-Oxon	834	829	784	634	334

B04

OP Pesticide	UNKNOWN				
	Concentration (M)				
	0.00E+00	1.00E-08	1.00E-07	6.00E-07	1.00E-06
Omethoate	408	407	398	348	308
Malaoxon	426	424	406	306	226
Dichlorvos	422	419	392	242	122
Chlorpyrifos-Methyl-Oxon	428	424	388	188	28
Pirimiphos-Methyl-Oxon	410	405	360	110	-90

B421

OP Pesticide	UNKNOWN				
	Concentration (M)				
	0.00E+00	1.00E-08	1.00E-07	7.00E-07	1.00E-06
Omethoate	612	609	582	402	312
Malaoxon	605	601	565	325	205
Dichlorvos	627	624	597	417	327
Chlorpyrifos-Methyl-Oxon	647	643	607	367	247
Pirimiphos-Methyl-Oxon	651	650	641	581	551

B65

OP Pesticide	UNKNOWN				
	Concentration (M)				
	0.00E+00	1.00E-08	1.00E-07	8.00E-07	1.00E-06
Omethoate	731	731	730	723	721
Malaoxon	764	764	763	756	754
Dichlorvos	734	734	733	726	724
Chlorpyrifos-Methyl-Oxon	766	766	765	758	756
Pirimiphos-Methyl-Oxon	700	700	699	692	690

As stated earlier, the basic data needed to be expanded significantly to provide training data for the neural network. This was achieved by simplifying the criteria for determining whether or not a particular pesticide was present or not. The desired training data was an input of six currents to produce six logic level outputs for whether or not a pesticide was present.

A spreadsheet was produced that produced two data sets for training. One set of input conditions produced results where a pesticide would be present. A simulated concentration (range from 100% of measuring range down to the detection limit at 0.1% steps, giving 1000 data points) was fed into a formula that produced a value for each of the six sensor currents. The currents assumed a linear relationship between the actual measured currents and concentration values, with a 2% random value added for noise. A sample of the spreadsheet is shown below.

Conc	WT	B02	B03	B04	B421	B65	0.001 Noise 2.00%							
							Upper	Lower	0	843	828	722	757	398
							1	-90	738	713	307	308	312	721
							WT	B02	B03	B04	B421	B65		
							Omethoate	Omethoate	Omethoate	Omethoate	Omethoate	Omethoate	Omethoate	Omethoate
0	827.5213	722.3761	762.6631	398.6661	578.7485	730.2163	0	0	0	0	0	0	1	0
0.001	827.4313	722.3671	752.2131	397.5761	576.4785	730.2073	1	1	1	1	1	1	1	1
0.998	736.7013	713.3941	302.5631	306.8461	310.2885	721.2343	0	0	1	0	0	0	0	1
0.999	736.6113	713.3851	302.1131	306.7561	314.0185	721.2253	0	0	1	0	0	0	1	1
1	736.5213	713.3761	298.6631	307.6661	312.7485	721.2163	0	0	0	0	0	0	1	0

The formulas for generating simulated currents are shown below.

$$=SLOPE(I\$2:I\$3,\$G\$2:\$G\$3)*\$A6+I\$2+RANDBETWEEN(-\$C\$1*(I\$2-I\$3),\$C\$1*(I\$2-I\$3))$$

where I\\$2:I\\$3 are currents taken directly from the original simulated data representing the maximum measuring range and limit of detection.

For each current generated from a simulated pesticide concentration, the spreadsheet then uses the original data to make the decision whether the pesticide is present or not. This is simply based on whether the current is between the limit of detection and the maximum measuring range. Any information on the magnitude of concentration is ignored, simply whether a given sensor current falls in the range of currents originally observed when a pesticide was present. The formula used is shown below.

```
=IF(($B6<I$2)*AND($B6>I$3),1,0)
```

Where I\$2 and I\$3 are the limits taken from the original data and \$B6 is the simulated current input for a simulated concentration of pesticide.

To complete the training data, the outcome of each sensor are logically AND'd together such that all six sensors must have detected a current which falls within the range where a particular pesticide is present for the combination of currents to produce a positive detection of the pesticide. The formula is shown below.

```
=IF(AND(I6,J6,K6,L6,M6,N6),1,0)
```

The spreadsheet was then expanded to produce 1000 combinations of current that generally indicated the presence of a particular pesticide, giving 6000 training points in total. This number of data points was found to give a good success rate when training the neural network (using a measure of success provided by the software package). The spreadsheet used is illustrated on the next page.

Conc	WT	B02	B03	B04	B421	B65	Omethoate	Malaoxon	Dichlorvos	Chlorpyrifos	Pirimiphos
0.014	826.2613	722.2501	755.3631	396.4061	576.9685	730.0903	1	0	0	0	0
0.015	827.1713	722.2411	750.9131	395.3161	572.6985	730.0813	1	0	0	0	0
0.016	827.0813	722.2321	755.4631	396.2261	575.4285	730.0723	1	0	0	0	0
0.996	738.8813	713.4121	314.4631	308.0261	312.8285	721.2523	1	0	0	0	0
0.997	736.7913	713.4031	310.0131	306.9361	308.5585	721.2433	0	0	0	0	0
0.998	736.7013	713.3941	302.5631	306.8461	310.2885	721.2343	0	0	0	0	0
0.999	736.6113	713.3851	302.1131	306.7561	314.0185	721.2253	0	0	0	0	0
1	736.5213	713.3761	298.6631	307.6661	312.7485	721.2163	0	0	0	0	0
0.516	749.1544	605.5507	651.5369	316.5042	376.3168	758.1068	0	1	0	0	0
0.517	748.9744	605.3707	652.1769	310.3242	382.9568	758.0978	0	1	0	0	0
0.518	751.7944	604.1907	642.8169	311.1442	377.5968	758.0888	0	1	0	0	0
0.519	747.6144	605.0107	641.4569	310.9642	384.2368	758.0798	0	1	0	0	0
0.52	746.4344	604.8307	650.0969	313.7842	370.8768	758.0708	0	1	0	0	0
0.521	748.2544	606.6507	648.7369	310.6042	384.5168	758.0618	0	1	0	0	0
0.998	665.3944	517.7907	470.0169	228.7442	200.7968	753.7688	0	0	0	0	0
0.999	664.2144	519.6107	469.6569	224.5642	209.4368	753.7598	0	0	0	0	0
1	663.0344	519.4307	476.2969	227.3842	206.0768	753.7508	0	0	0	0	0
0.039	831.2153	729.9247	812.6086	382.5755	583.161	732.6312	0	0	1	0	0
0.04	831.9453	729.8977	812.5996	376.3055	584.891	732.6222	0	0	1	0	0
0.041	822.6753	729.8707	812.5906	378.0355	587.621	732.6132	0	0	1	0	0
0.042	822.4053	729.8437	812.5816	384.7655	588.351	732.6042	0	0	1	0	0
0.043	822.1353	729.8167	812.5726	383.4955	590.081	732.5952	0	0	1	0	0
0.044	820.8653	729.7897	812.5636	385.2255	581.811	732.5862	0	0	1	0	0
0.045	820.5953	729.7627	812.5546	382.9555	579.541	732.5772	0	0	1	0	0
0.046	827.3253	729.7357	812.5456	379.6855	587.271	732.5682	0	0	1	0	0
0.282	685.0529	687.5748	798.2538	282.336	505.0469	762.7006	0	1	0	1	0
0.283	686.6929	687.5388	798.2448	292.976	498.6869	762.6916	0	1	0	1	0
0.284	679.3329	687.5028	798.2358	283.616	497.3269	762.6826	0	1	0	1	0
0.285	687.9729	687.4668	798.2268	279.256	497.9669	762.6736	0	1	0	1	0
0.286	684.6129	687.4308	798.2178	283.896	504.6069	762.6646	0	1	0	1	0
0.287	685.2529	687.3948	798.2088	284.536	505.2469	762.6556	0	1	0	1	0
0.288	684.8929	687.3588	798.1998	288.176	503.8869	762.6466	0	1	0	1	0
0.289	681.5329	687.3228	798.1908	284.816	507.5269	762.6376	0	1	0	1	0
0.437	614.6084	688.5696	588.9499	171.1555	601.9371	695.3859	0	0	0	0	1
0.438	614.1584	688.5246	587.4999	155.7055	600.8471	695.3769	0	0	0	0	1
0.439	629.7084	688.4796	595.0499	160.2555	600.7571	695.3679	0	0	0	0	1
0.44	627.2584	688.4346	587.5999	161.8055	602.6671	695.3589	0	0	0	0	1
0.441	630.8084	688.3896	594.1499	156.3555	601.5771	695.3499	0	0	0	0	1
0.442	629.3584	688.3446	585.6999	165.9055	601.4871	695.3409	0	0	0	0	1
0.443	615.9084	688.2996	577.2499	156.4555	600.3971	695.3319	0	0	0	0	1
0.444	617.4584	688.2546	585.7999	167.0055	600.3071	695.3229	0	0	0	0	1
1	371.2584	663.2346	342.5999	-87.1945	550.2671	690.3189	0	0	0	0	0

The other set of data generated for training the neural network was a similar quantity (6000 data sets) of current combinations which would not indicate the presence of a pesticide. These were produced using randomly generated values for current and the same criteria for indication of a pesticide present or not. The closer the output value to numerical 1.0 indicated a high probability that the pesticide were present. Similarly, if the output is close to zero, then there is a low probability of the pesticide being present. As no actual data was available, the neural network was tested by feeding back in a similar set of data points but with new random values added into the spreadsheet.

As no actual data was available, the next stage of the process (determining the level of pesticide present) was not tried. However, this would be achieved by using the best (from the original data) sensor response for each pesticide and biosensor to produce a traditional calibration curve. The accuracy of this would depend on performance of the sensors, which could not be simulated.

Results

The final neural network configuration with all training data applied is shown below. The learning curve showed low errors, indicating successful training of the neural network.

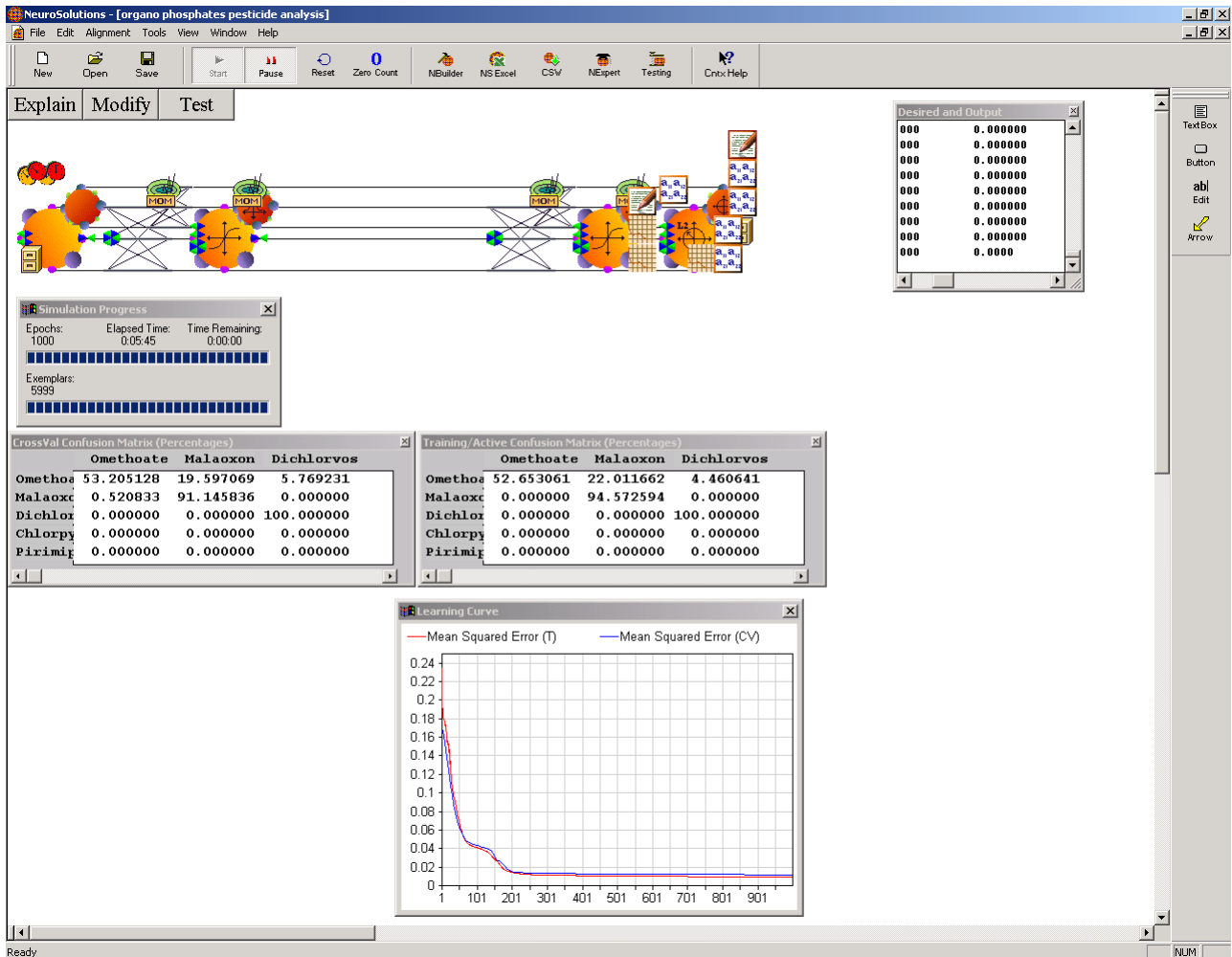

The results of applying various current combinations for one pesticide presence are shown below as a radar diagram. Here the pesticide omethoate is used to test the model. The diagram is divided into two segments, representing the absence or presence of the pesticide. The absence of pesticide is represented as 0 and the presence as 1. The dark blue trace on the diagram represents the “true” answer and the pink coloured trace is the output when test data is analysed by the neural network. Where the pink trace overlies the dark blue trace the results has been correctly identified. The out lying “points” on the left hand side of the diagram are incorrect. It can be seen that over 95% of the data has been correctly categorised.

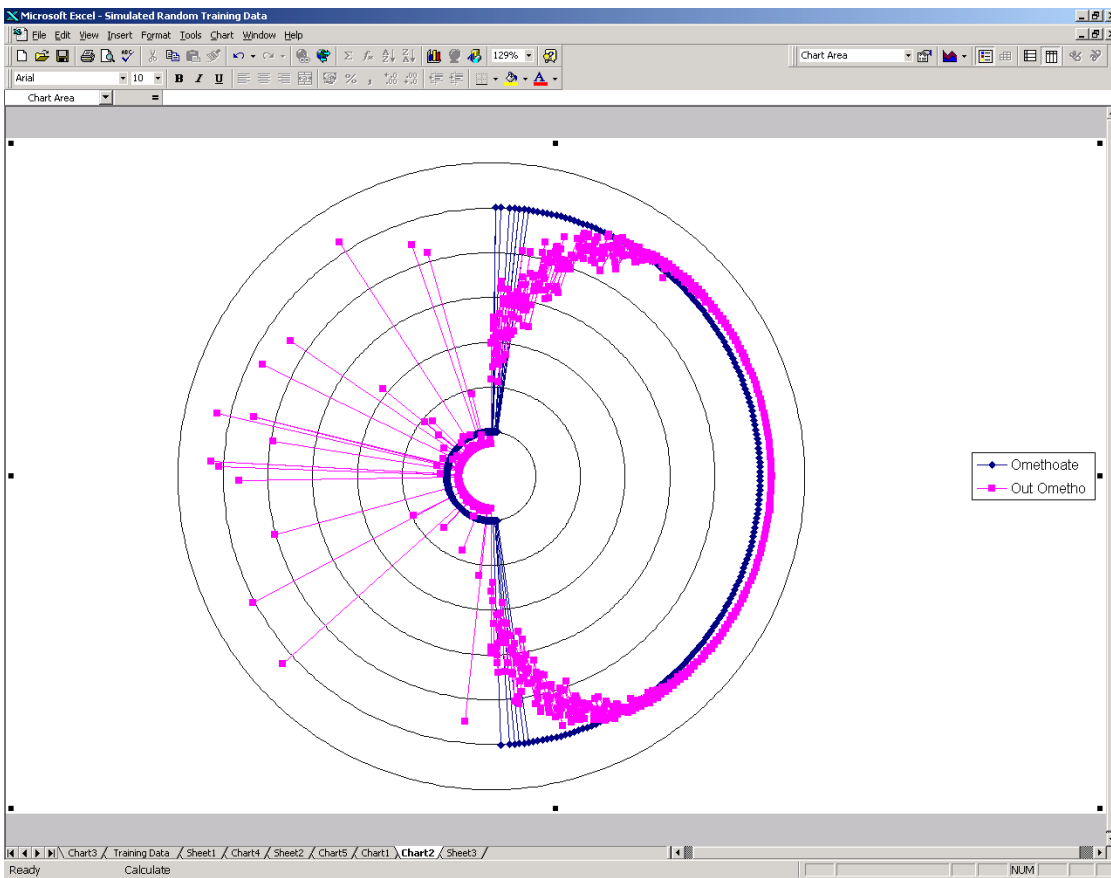

The exercise was repeated for all five pesticides that will be detected in the final instrument. The diagram shows the expected answers and the output from the neural network. The right side of the diagram represents the presence of pesticide while the left is the absence. Each sector corresponds to one pesticide and the points on the left side of the diagram represent false positives.

Organo Phosphates Pesticide Analysis Results

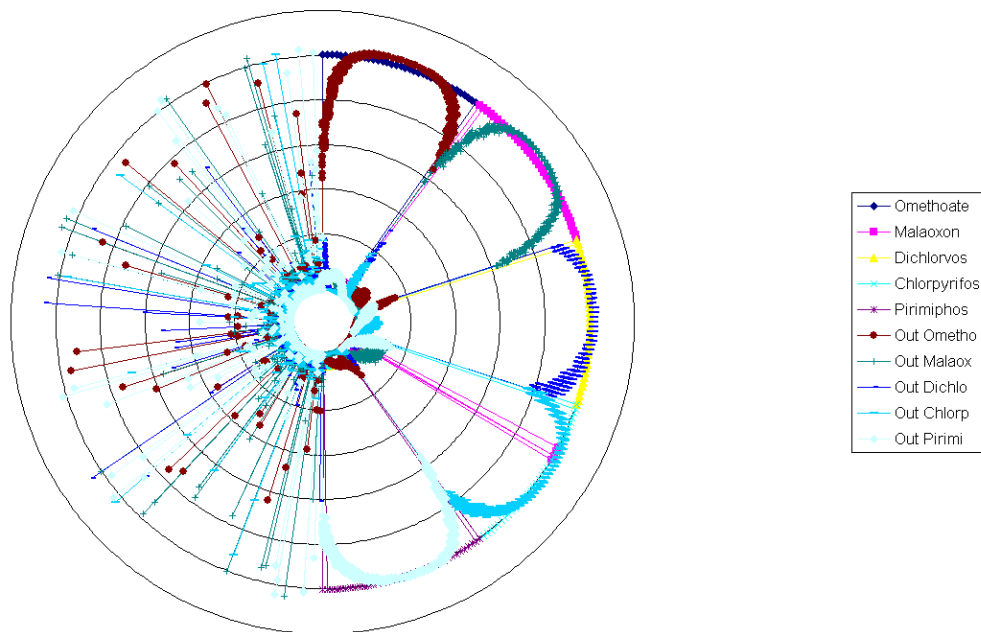

Discussion

The results clearly show that the neural network is capable of determining which pesticide is present based on the output of the array of biosensors. The software package interfaces to the data with simple text files, making data input from the instrument easy. The output is also clear and represents a probability of a particular pesticide being present. Although there are some instances where the neural network gives an indication of pesticide presence when the simulated data suggests that no pesticide is present, this represents a “fail safe” scenario that in practise would lead to further tests.

The neural network has been demonstrated using simulated data. This has however been based on real data, but in the absence of sufficient training data it is impossible to verify the actual performance of the system. However, the spreadsheet models used to generate training data are directly applicable to real data. The key assumption that would need to be investigated further relates to whether or not a calibration curve of current versus concentration for a given biosensor and pesticide can be constructed. For the simulated data, this was assumed to be log-linear, but any relationship could be applied (for example, quadratic or third order polynomial). Similarly, adding random noise simulated the degree of uncertainty. This would be equated to the actual uncertainty found for the complete system.

Conclusions

The neural network programme can be used in conjunction with a biosensor array to identify particular extracted pesticide residues.

References

Professor Gary Montague
Professor of Bioprocess Control
School of Chemical Engineering and Advanced Materials
University of Newcastle
Newcastle upon Tyne, NE1 7RU
England

Technical detail 5 – Prototype instrument development and fabrication

Introduction

The analysis instrument interfaces with the biosensor array and uses a six-input potentiostat to measure using chronoamperometry the signals from the biosensor array. These are then downloaded to a PC based data processing system to provide the analysis results. The analysis instrument also incorporates the necessary fluidics to present the required sample and solutions to the sensor array. The instrument provides a portable, integrated approach, and is based on a generic instrumentation platform. The system is intended to be used by semi-skilled personnel, has a low cost of ownership, operation and maintenance.

Objectives:

- To define instrument specifications
- To develop and produce a prototype instrument for end user evaluation.

Instrument specification

The key performance parameters for the potentiostat are defined below.

Range:	$\pm 30\mu\text{A}$
Resolution:	1nA
Accuracy:	$\pm 1\text{nA}$, $\pm 0.1\%$ of Reading (whichever is greater)
Potential:	-1.000V to +1.000V with respect to Reference Electrode
Resolution:	1mV
Accuracy:	$\pm 1\text{mV}$

The instrument consists of the following main component blocks: -

A sensor array cell block.

Six isolated potentiostat signal conditioning circuits.

Fluid handling system (to pump sample, buffer and acetyl thiocholine to the array).

A microprocessor to control the instrument functions.

A power supply.

A thermostat heater and controller.

An interface to down load data to a PC for analysis.

Casework to house the above.

Sensor Array Cell Block

The sensor array cell block was initially designed to accommodate a circular disc assembly that housed six biosensors, as shown in figure 13.

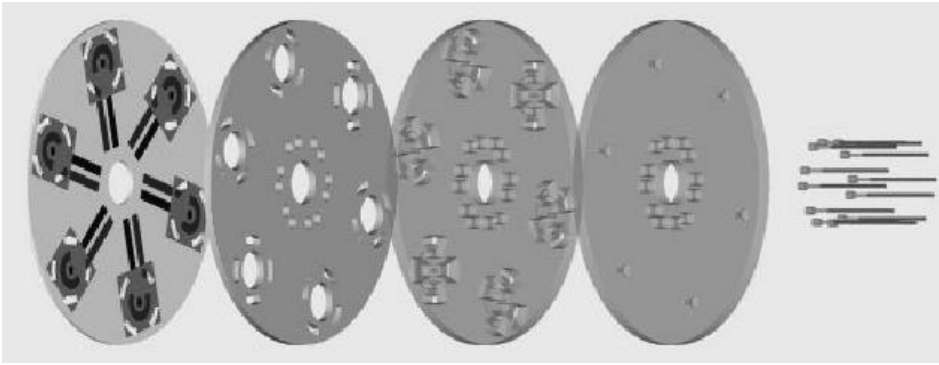

Figure 13. Exploded view of the circular sensor housing.

However, this was changed to a linear configuration to allow individual biosensors to be used on the instrument. A two by three configuration was initially tried. This was machined from Aluminium and then anodised to provide an insulating coating. Aluminium was chosen to achieve the required mechanical strength and machining accuracy (the sample volume was specified at 80µl). Aluminium also provided good thermal contact between the sample chamber blocks and the heater block. This design is illustrated in figure 14.

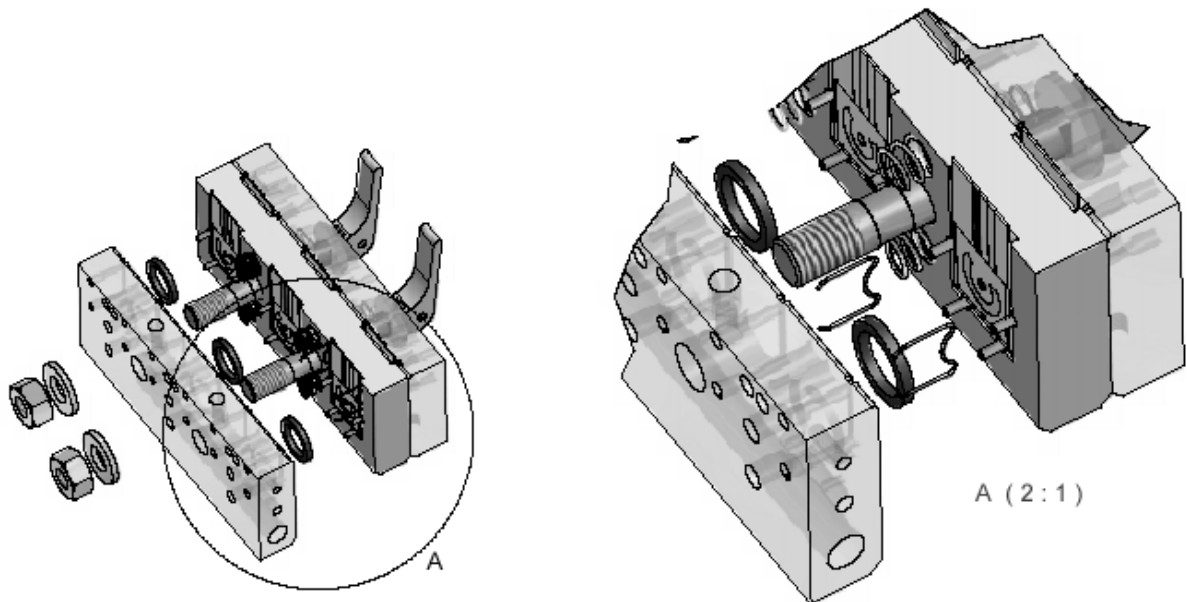

Figure 14. View of a 2 x 3 electrode housing.

The initial block design had a number of shortcomings (see Results section). The specification was changed to allow a greater sample volume to be applied to the sensor surface. It was decided to re-design the cell block configuration to a linear six position array. In the latest configuration, the sample chambers are machined from clear Perspex to allow sample flow to be observed. This is mounted onto an Aluminium block that houses the heaters such that the base of the sensors is heated. Various configurations of sample chamber were tried to minimise the effects of bubbles on the sensor surface before arriving at the current profile. The final block design is shown in figure 15.

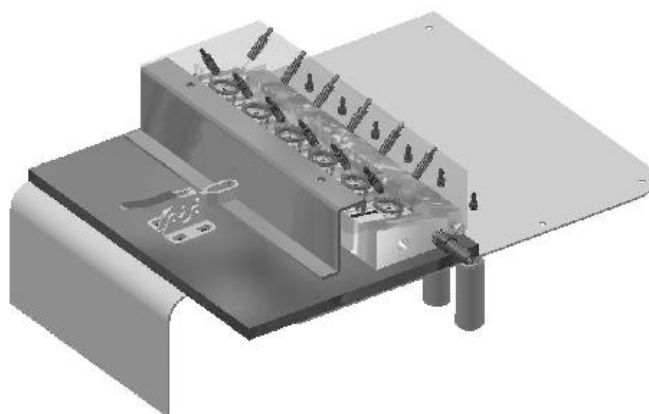

Figure 15. View of linear electrode housing.

Six isolated potentiostat signal conditioning circuits

The potentiostat circuits use a 12-bit digital-to-analogue converter to generate the reference voltage. A level translation op-amp configuration allows this to be set to any value between -1000mV and $+1000\text{mV}$ with a resolution to 1mV . The sensor current is converted to a voltage using a low-noise, high impedance op-amp configuration. After level shifting, a 12-bit analogue-to-digital converter digitises the sensor signal. Because six identical potentiostat signal-conditioning circuits are required it is necessary to provide galvanic isolation between the circuits to prevent possible interference between circuits. Isolation is achieved in the digital domain through the use of optical isolators' in-line with the control signals for the analogue-to-digital converter and digital-to-analogue converter. An optically isolated DC-DC converter generates power for the potentiostat. A separate 5V switch-mode circuit on the power supply board powers the DC-DC converter. The printed circuit board layout and circuit schematic are shown in figure 16.

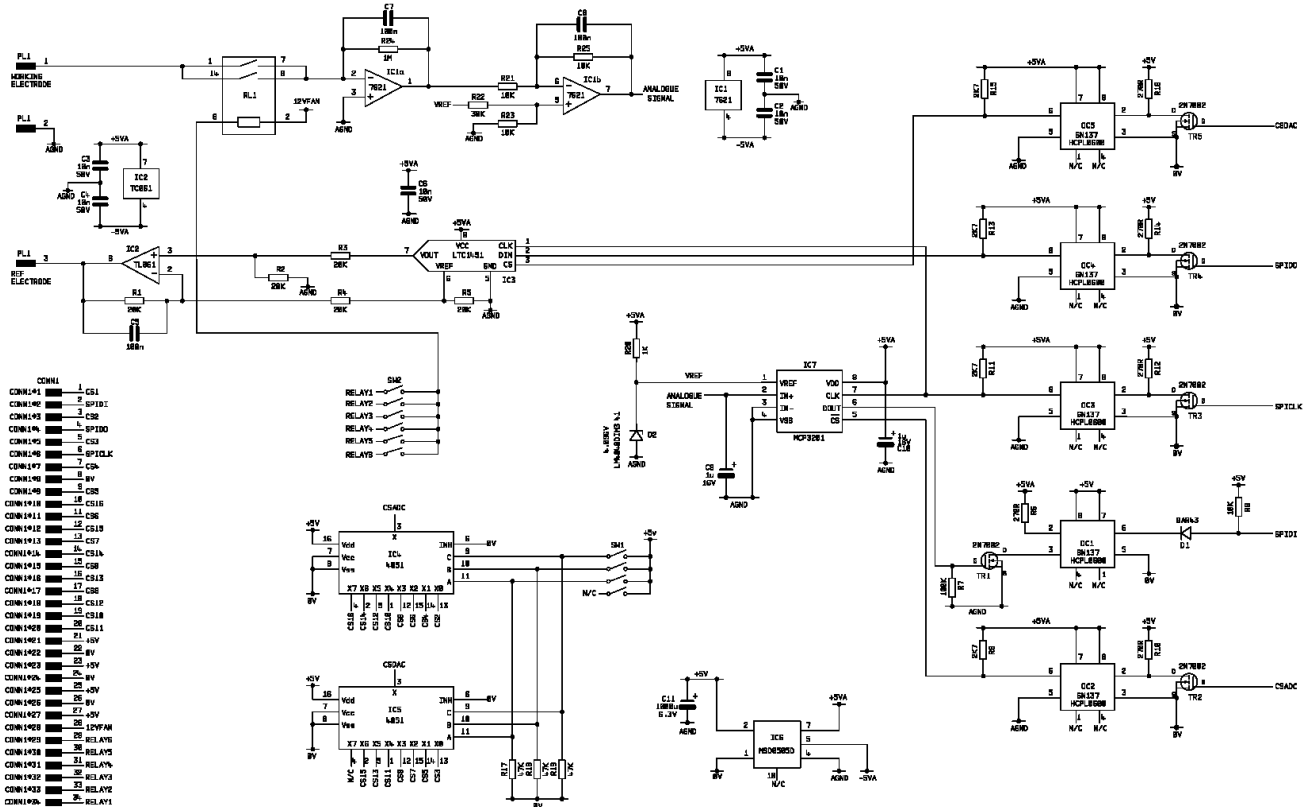
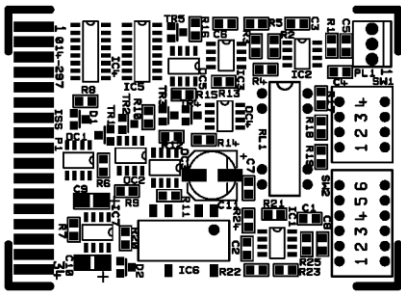

Figure 16. The printed circuit board layout and circuit schematic.

The instrument is configured to take up to six potentiostat circuit boards. These plug directly into a common edge-connector system that feeds into an interface board. The function of the interface board is to expand the signals from the microprocessor to allow control of the internal peripherals (including the potentiostat circuits). This is described more fully under the microprocessor section.

Fluid handling system

The instrument contains all of the necessary hardware to pump sample, buffer and acetyl thiocholine to the biosensor array and to collect the associated waste. A diagram of the system is shown in figure 17.

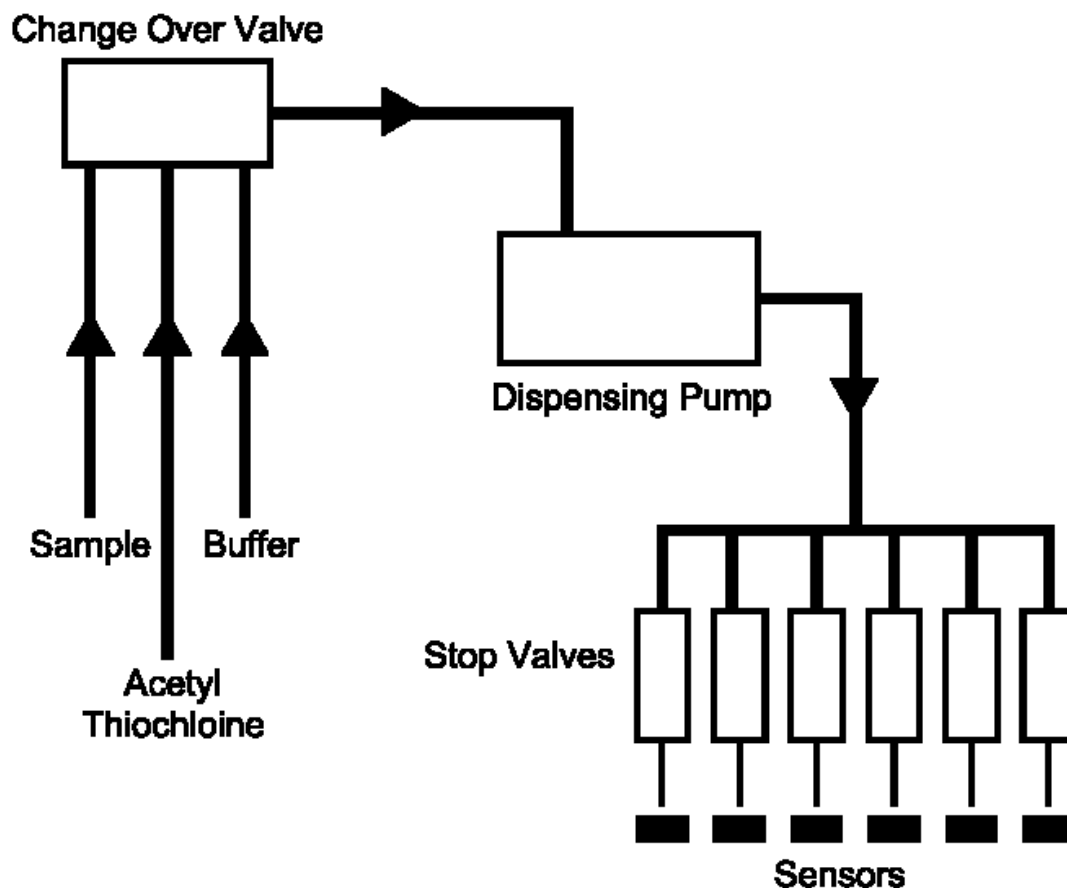

Figure 17. Diagram of the fluidics system.

The system is based on a displacement pump supplied by The Lee Company (a US based manufacturer of Electro-fluidic systems). A displacement pump was chosen to achieve the required accuracy in sample volume delivery. The pump has a total capacity of 1250 μ l and dispenses 2.5 μ l per step (the pump is electrically controlled like a stepper motor, such that individual pulses can be applied or a continuous flow achieved by repeated pulses). The variable-dispense volume provided by this type of pump yields greater system flexibility. Variable flow rates can also be achieved through software by varying the pulse rate to the pump. Inlet and outlet control is provided by a combination of stop valves and changeover valves. Again these were sourced from The Lee Company.

The first configuration used a series of valves connected by tubing. Manifold mounted valves located on a Perspex distribution block to feed into the sensor block subsequently replaced this. This configuration reduced the volume in the system to speed up the analysis time and is illustrated in figure 18.



Figure 18. View of manifold mounted valves.

Microprocessor system

The instrument functions (fluid handling, signal measurement and data exchange) are all controlled by a microprocessor. The microprocessor used is the H8-325, manufactured by Hitachi. This is a 16-bit microprocessor running with a 12MHz-system clock. The microprocessor executes software from an 8-bit data bus EPROM. The software is written entirely in the 'C' programming language and was compiled into executable code using IAR development tools.

The microprocessor interfaces to the peripheral devices within the system through the integrated input/output ports on the device. Because of the large number of control signals required an interface circuit board was added to the system. A serial data stream is generated by the microprocessor that is clocked into a cascaded

array of shift registers. Using this approach, multiple output signals are produced using only three signals from the microprocessor. This minimises the connections and improves noise immunity.

The display mounted on the instrument provides user feedback on instrument status. As a PC ultimately controls the system, this display is not directly required. It was retained to facilitate development of the embedded software and to provide feedback independent of the PC based software. The display is a generic module used on other instruments. A segmented display controller, manufactured by Hitachi generates LCD drive signals. This interfaces to the microprocessor using the parallel data and address bus. An over view of the analysis algorithm is seen in figure 19.

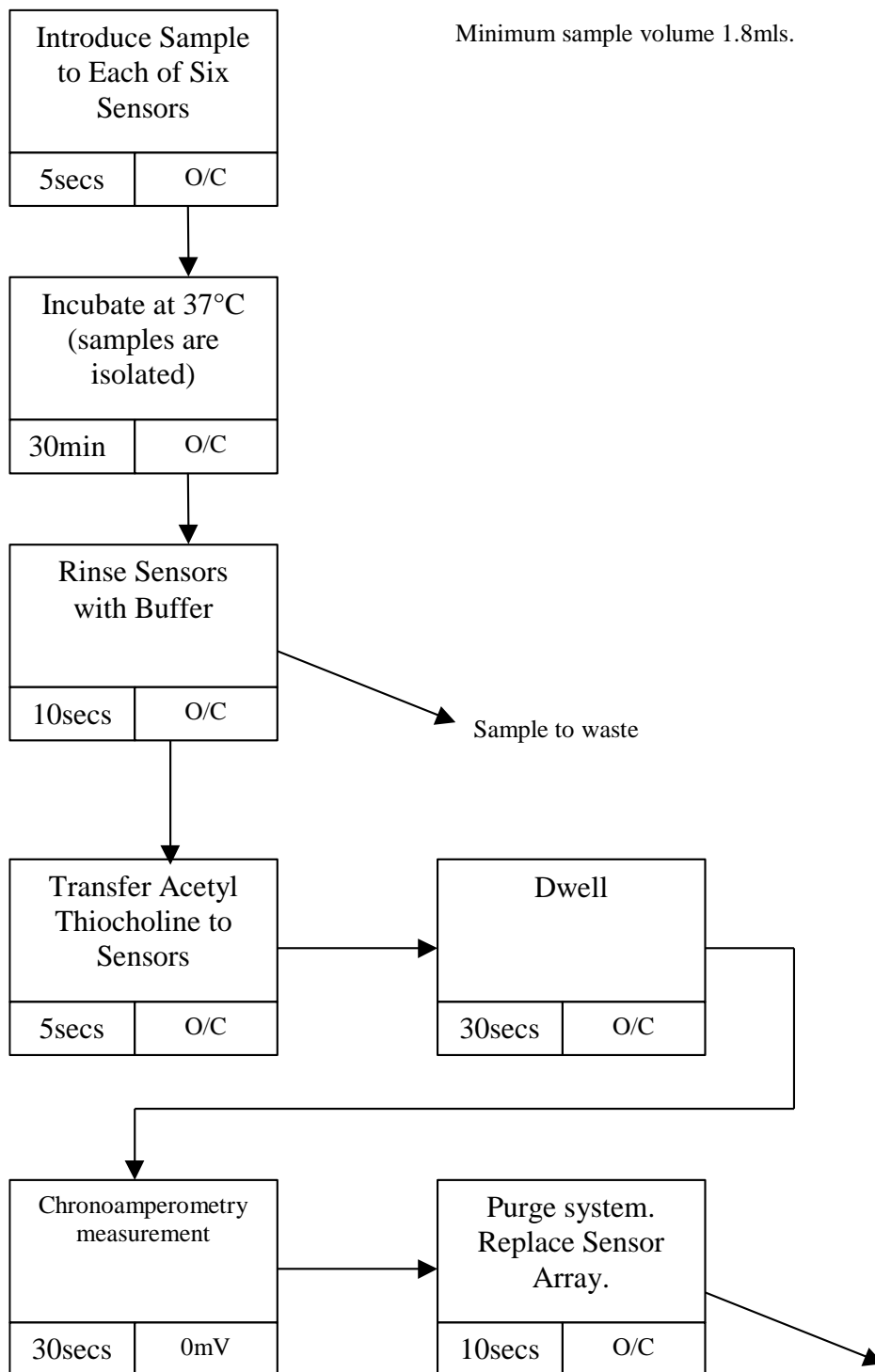

Figure 19. The microprocessor and software analysis algorithm.

Power supply

The main system power supply is housed on a single printed circuit board. This board also holds the stepper motor drive circuits used to drive the displacement pump. A constant-current stepper motor configuration is used to provide maximum torque and flow-rate capability from the pump. This is supplied directly from a 30V supply (see below), even though the pump is rated at 12V. The constant current circuit limits power supplied to the pump to maintain safe operation.

The power supply uses a common 30V-supply rail for most of the system peripherals. This is a smoothed and rectified voltage produced on the power supply board from the main transformer secondary winding. A switch-mode 5V regulator generates power for the digital circuitry. Power for the interface circuit is generated by a separate linear 5V-regulator fed from the other transformer secondary (9Vac). This configuration provides maximum flexibility in the system configuration by making the interface board a discrete functional module.

Power for the valves used in the system is generated by a 12V switch-mode regulator, which is supplied from the common 30V-supply rail. A configurable 5V/12V-switch mode regulator provides power for the optically isolated DC-DC converters housed on each of the potentiostat circuit boards. The main 5V regulator does not have enough capacity to supply the current requirements of six potentiostat circuit boards, hence the use of a separate regulator circuit.

Thermostat heater and controller

A proprietary temperature controller (supplied by RS Components, part number 292-0221) is used to maintain the sample block at 37°C. The thermostat controls two mains voltage cartridge heaters (supplied by RS Components, part number 731-215) that are housed within the Aluminium sample block. The temperature sensor (supplied by RS Components, part number 237-1607) that provides feedback to the thermostat is also housed within the sample block. The thermostat is powered directly from the mains supply within the instrument and does not interface with any other system components.

PC Interface

The instrument interfaces with the data analysis PC using an RS232 compatible serial interface. The physical layer is provided by an integrated RS232 transceiver that connects to a 25-D type socket at the rear of the instrument. The connections support null-modem connection to the PC thereby allowing use of a straight-through connection cable to the PC. The microprocessor contains an on-board universal asynchronous serial adapter that is controlled directly by the software.

In addition to result data download by the analysis PC based software, the PC interface also allows configuration of the instrument platform. A protocol using ASCII data formats provides the mechanism for data exchange within the protocol.

Casework

The casework used for the instrument is that used on the Jenway model 6300 spectrophotometer. The mounts for mains connection, PC connection, display and keypad are standard on the case used. The case also contains mounts for the power supply and microprocessor boards. The case was modified to replace the spectrophotometer sample chamber with the fluid handling system and biosensor sample block. The additional casework was fabricated using sheet metal.

Initial evaluation

Test results with the initial configuration showed excessive variability when used with the same sensor. It was suspected that air bubbles becoming trapped on the sensor surface caused the variation. This was impossible to verify with the initial two by three sample block configuration. When the clear Perspex block design was evaluated, it was observed that air bubbles trapped on the sensor surface were not displaced by the sample flow. The option of using a wetting agent was not considered acceptable. Although it was not possible to completely eliminate bubble effects within the sample chamber area, the latest cell design minimised the effects.

The potentiostat circuits were tested electrically by configuring the reference voltage to various levels between the upper and lower specifications. The voltages were measured with respect to both circuit ground and the virtual earth created by the current to voltage converter front end. The measured potentials were within 2mV of the expected level (measured with an Avometer model M3004 3½ digit digital multi-meter).

Electrical operation of the potentiostat circuits was tested using a known resistance (1Mohm 0.1% tolerance) connected between reference electrode input and the working electrode input. Various reference potentials were then applied and the associated current readings noted. Linearity was within specification. The absolute currents were typically within 1% of the expected value.

Discussion

The current instrument configuration meets the specified requirements. As would be expected, the changes identified as the project developed necessitated deviation from the original specification. Based on the current configuration it would be possible to improve the system further. The fluid handling system was chosen because of the specified need to dispense accurate volumes to the biosensor. Stop valves were incorporated to provide physical isolation between the potentiostat circuits, as well as to control flow of solution to each biosensor. If the fluid handling system were replaced by an alternative pumping method and

flow to the sensors arranged such that solution was delivered in parallel rather than in series, the lack of isolation would need to be investigated. Apart from this, the change in specification that removed the precise limits on sample volume delivered to each biosensor negated the main advantages of a displacement pump system.

The control system provides all of the functionality required for the instrument. The layout could be improved, but the basic architecture is adequate. Rationalisation of the power supply circuitry is possible, but would depend on any changes to the fluid handling system. Similarly, alternative display technology could be employed if more status information were deemed necessary; status indicators could equally replace the display if less information were required.

Conclusions

An instrument with the necessary specification can be fabricated to hold six electrodes and perform all fluidic and electrochemical operations.

Technical detail 6 – End-Used Evaluation of Pesticide Biosensor

Introduction

This section describes the end-user evaluation of the technology. Guidance on end-user system specifications was based on requirements from commercial cereal intake facilities. This suggested that the total analysis time would need to be around 10-15 minutes (i.e. typical turnaround time of a bulk grain delivery), and that the instrument would not need specialist equipment/facilities or hazardous solvents.

Materials and Methods

Equipment and reagents

The extraction system was developed by CCFRA/Jenway, and Phytosol was obtained from Advanced Phytonics Limited.

Five types of electrode were fabricated by GEM/AET with mutant acetylcholinesterase enzymes coded B03, B04, B65, B131 and B421 immobilized onto a screen-printed carbon electrode. A sixth enzyme type B02 was unavailable because of problems associated with immobilisation.

The prototype biosensor instrument was developed and built by Jenway, and was delivered with five working electrode positions (the sixth position was dead electrically).

Organophosphorus pesticide standards (chlorpyrifos-methyl, chlorpyrifos-methyl oxon, dichlorvos, malathion, malaoxon, omethoate, pirimiphos-methyl, and pirimiphos-methyl oxon) were purchased from QMX Limited or gifts from the University of Perpignan.

All other reagents were of Analar quality or better.

Pesticide recovery

Pesticide free wheat (10g) was milled coarsely and spiked with 5 pesticides (chlorpyrifos-methyl, dichlorvos, malathion, omethoate, and pirimiphos-methyl), all at 5 mg/kg (i.e. 5 ppm). This is typical of MRLs for organophosphorus pesticide in cereals. The spiked wheat was placed in the extraction vessel, and Phytosol was added through the specially designed aerosol inlet valve until it covered the wheat. The contents of the extraction vessel were left to stand for 2 minutes with occasional shaking. The liquefied gas extract was delivered through the aerosol inlet to a 10 ml volumetric flask, and the contents in the extraction vessel were re-extracted using Phytosol. The second extraction was added to the same volumetric flask. Phytosol solvent was allowed to volatilise and the contents were made up to 10 ml using hexane.

The percentage recovery of pesticide was determined using a gas chromatography based method according to UKAS accredited pesticide determination method (Weetabix analytical method A066).

Prototype biosensor instrument

The prototype instrument required three solvent feeds (i.e. phosphate buffer, analytical sample and acetylthiocholine). The fluid delivery duration and volumes in all of the reaction chambers were measured using coloured water solutions to ensure that chambers were filled without the formation of bubbles and that there was no sample carry-over from feeds or from run-to-run.

Electrodes were placed in each of the five chambers. Five of the same type of electrode was used for practical reasons (five combinations of different electrode types could equally be used). The feed solutions (i.e. phosphate buffer, thiocholine, and pesticide samples) were prepared fresh each day.

Electrodes were placed in the instrument and the chambers were clamped to prevent leaks. The following biosensor instrumental settings, which were automatically controlled by the prototype instrument, were used in all analysis;

1.25 ml of analytical sample loaded into each chamber

↓

Incubate for 3 minutes at 37°C

↓

Wash each cell with 1.25 ml of buffer

↓

Load each cell with 1.25 ml of acetylthiocholine

↓

Measure current at 10 seconds

↓

Wash cell with 1.25 ml of buffer

Measurement of electrode activity/repeatability

Five electrodes of the same type (i.e. B03, B04, B65, B131 or B421) were placed into each of the five working cells in the prototype instrument. The analytical protocol as outlined above was followed, and pesticides in the oxon form (i.e. chlorpyrifos-methyl oxon, dichlorvos, malaaxon, omethoate and pirimiphos-methyl oxon) at concentrations of 0, 1 or 5 mg/kg were presented to each chamber. Ten replicate determinations were performed on each type of electrode.

Sample extraction and inhibition assay

Separate samples of pesticide free wheat (10 g) were spiked with either 0 or 5 mg/kg of chlorpyrifos-methyl, dichlorvos, malathion, omethoate and pirimiphos-methyl. Wheat samples were placed in the extraction vessel, Phytosol was introduced through the special aerosol nozzle until the wheat was just immersed in liquefied gas solvent, and the sample was extracted for 2 minutes with occasional shaking. The extract was transferred from the reaction chamber to a 50 ml plastic V-shaped tube. The contents in the extraction vessel were re-extracted, and this material was added to the same V-shaped tube. Phytosol was allowed to volatilise from the combined extracts, which was then transferred to a vial (using 0.5 ml of methanol) and made up to 10 ml with phosphate buffer. Sodium hypochlorite (500 µl, 0.06 M) was added to oxidise the pesticides. Biosensor inhibition profiles were determined using 5 biosensors of the same type placed in the 5 positions in the instrument.

Results

Pesticide recovery

Table 4 presents the average recoveries of chlorpyrifos-methyl, dichlorvos, malathion, omethoate, and pirimiphos-methyl from wheat spiked at 5 mg/kg.

Table 4. Pesticide recoveries

Pesticide	Recovery (%)	Relative standard deviation
Chlorpyrifos-methyl	76	11
Dichlorvos	85	13
Malathion	81	9
Omethoate	77	10
Pirimiphos-methyl	82	10

These recoveries were acceptable, and are similar to those that could be obtained using a longer duration conventional organic solvent extraction. The chromatograms showed the presence of co-extracted material from the wheat, but the results demonstrate that the novel rapid extraction recovered the pesticides.

Electrode activity/repeatability

Figure 20 shows biosensor repeatability following exposure to 0, 1 and 5 mg/kg of chlorpyrifos-methyl oxon, dichlorvos, malaaxon, omethoate and pirimiphos-methyl oxon in phosphate buffer.

Biosensor currents in the absence of pesticide were between about 60 and 250 nA. Biosensor currents decreased in the presence of 5 mg/kg of pesticide, showing that enzyme inhibition had occurred. Different patterns of inhibition were produced by the pesticide/biosensor combinations. However, the poor precision

of the batch of test electrodes meant that relatively large decreases in current were required in order to detect a real response. Pesticides at 1mg/kg did not give a reduction in response that was statistically different to that of the control, so lower concentrations were not screened.

In general, biosensors were most sensitive to dichlorvos, malaoxon and chlorpyrifos methyl oxon. Biosensor type B421 was the more sensitive to dichlorvos and malaoxon and showed some sensitivity for chlorpyrifos-methyl oxon. It was not inhibited by omethoate or pirimiphos methyl oxon. Biosensor types B03 and B131 showed the best spectrum of inhibition, giving good responses to dichlorvos, malaoxon and chlorpyrifos methyl oxon, and dichlorvos and omethoate, respectively. There was also partial inhibition to the other pesticide oxons. Biosensor type B04 responded to dichlorvos and malaoxon, but biosensor type B65 responded to malaoxon only.

Sample extraction and inhibition assay

Figure 21 shows the responses of the electrodes to dichlorvos, chlorpyrifos-methyl, malathion, omethoate and pirimiphos-methyl that had been spiked (5 mg/kg) into pesticide free wheat, extracted using Phytosol and oxidised before analysis (i.e. all transformed into the oxon form). Biosensor currents produced by buffer solutions (i.e. no pesticide) were in the range 50-220 nA. These values were generally lower than the ones obtained in the repeatability study, and might just reflect poor biosensor repeatability and possibly some electrode-associated aging effects. Biosensor type B421 was clearly inhibited by dichlorvos and omethoate. Biosensor type B131 was inhibited by omethoate, while B03 and B65 were both inhibited by malaoxon (i.e. malathion). However, none of the pesticides produced significant inhibition with biosensor type B04.

Due to time constraints it was not possible to investigate possible causes for this apparently poor inhibition. Comments on ease of use and meeting requirements of industry are provided in the discussion.

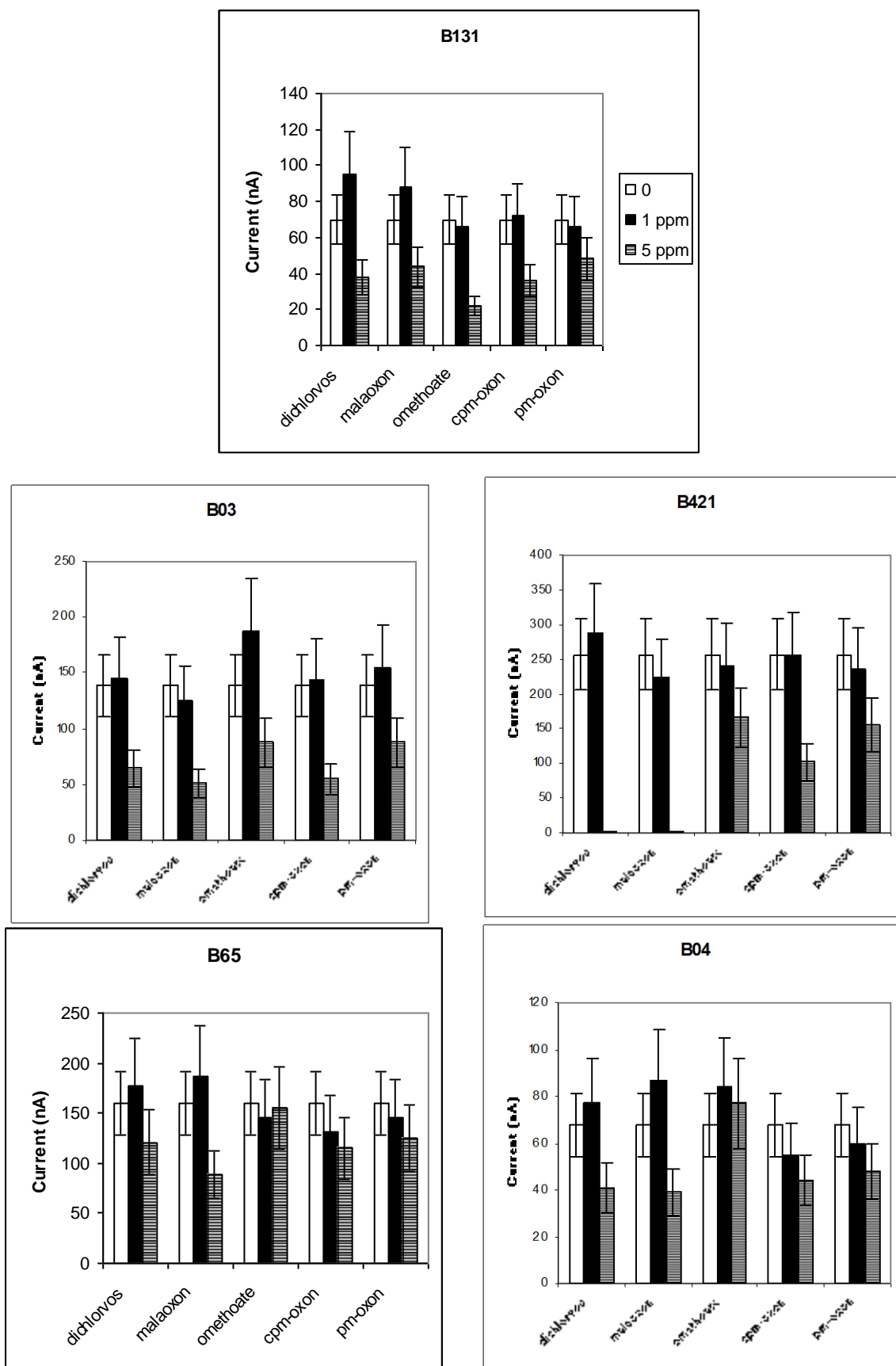

Figure 20. Electrode biosensor repeatability following exposure to 0, 1 and 5 mg/kg (i.e. ppm) of organophosphorus pesticides in the oxon form in buffer solution.

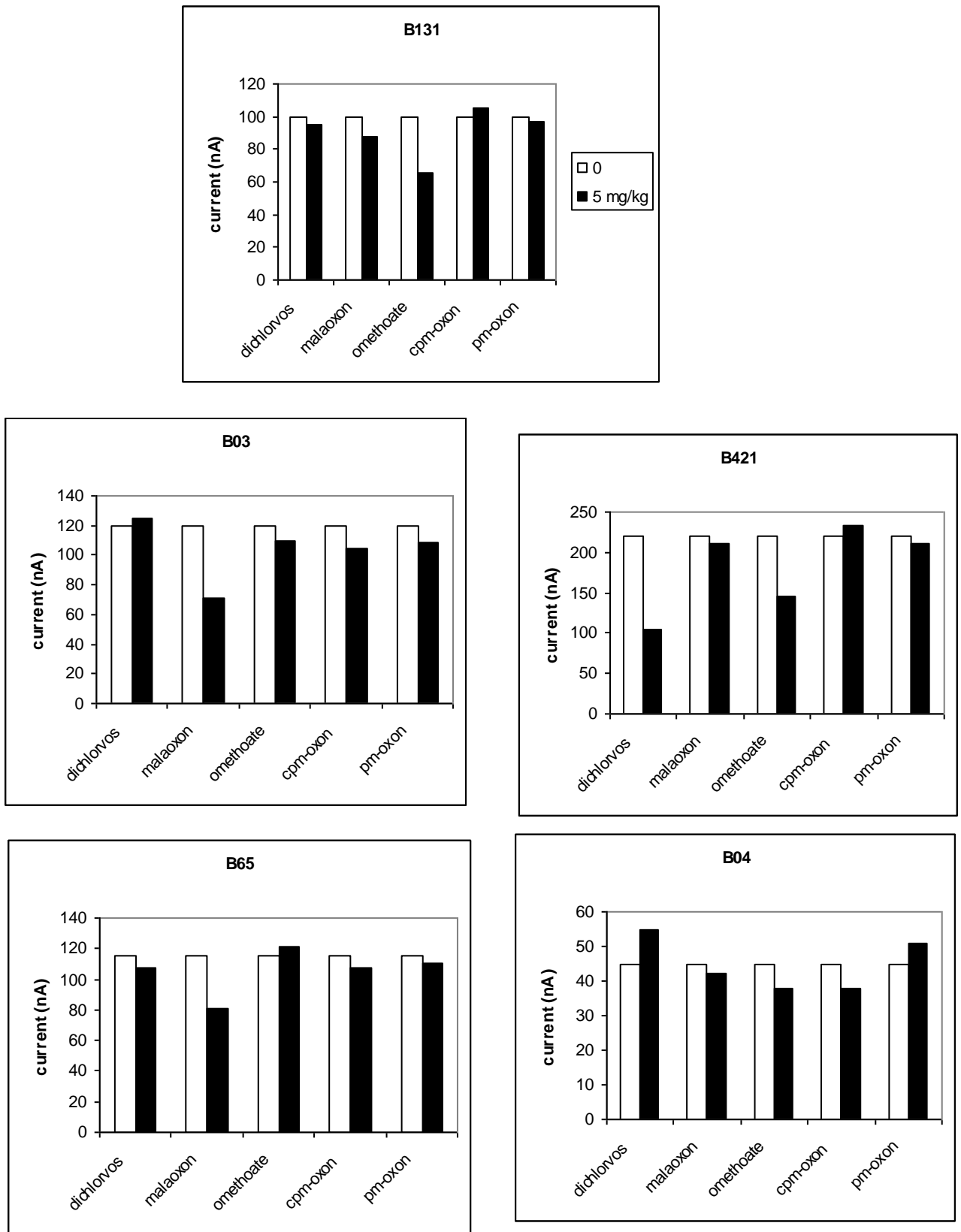

Figure 21. Electrode responses to pesticides recovered from spiked wheat (5 mg/kg) following extraction with Phytosol and oxidation.

Discussion

This phase of the project brought together the whole analytical system for evaluation by the end user. The various aspects of the system and how they performed in the evaluation are given below.

Extraction

The novel extraction method was shown to be quick and straightforward and it gave recoveries similar to those from conventional organic solvent extraction, suggesting that it might also be suitable for extracting other contaminants from food. It was one of the earlier successes of the project.

Electrode activity/repeatability

Using standard solutions (i.e. pesticides in the oxon form in buffer solution), there is evidence that the electrode/pesticide combinations produce a response pattern that will enable the identity and quantity of organophosphorus pesticides to be determined using appropriate pattern recognition software. Electrodes with immobilized enzymes B421 and B03 were most sensitive to dichlorvos and malaoxon, while B03 was also inhibited by chlorpyrifos-methyl oxon. Enzyme B131 was more sensitive to omethoate followed by dichlorvos and chlorpyrifos-methyl oxon. B03 electrodes were sensitive to pirimiphos-methyl (i.e. the most common grain store protectant organophosphorus pesticide). B04 showed some specificity for dichlorvos and malaoxon, and B65 was sensitive to only malaoxon. The pattern of inhibitions suggests that electrodes could be developed that are specific for a certain pesticide (e.g. B65), or that respond to a wide range of organophosphorus pesticides (e.g. B03). Electrode repeatability issues need to be addressed if this is to become practicable. Electrode precision also needs to be improved so that the output can be used in a pattern recognition program (e.g. neural network), so that even the small differences could be used to identify enable pesticide structure and quantity.

The performance of the whole system (i.e. extraction and analysis) was not as good as that obtained with authentic pesticide standards solutions, and there were also some differences in electrode inhibition patterns. There are a number of possible reasons, including biosensor repeatability issues, interference in response caused by co-extracted food compounds and problems with the oxidation step.

Co-extracted food components could inhibit or degrade the immobilized acetylcholinesterase enzyme. However, earlier work at UWE indicated that co-extracted material had a protective effect on enzyme activity (i.e. higher base currents were obtained). The oxidation step is more likely to be the source of the problem, and needs to be optimised to ensure that there is sufficient oxidising agent to oxidise the pesticides to their oxon forms, but not so much as to further oxidise the oxon, or degrade the immobilized enzyme.

Further work needs to be undertaken in order to measure the false-positive/false-negative rate and the instrumental response to mixtures of pesticides. This is probably more important for fruits and vegetables where there is a greater risk of multiple pesticide residues.

In order to meet the needs of the food industry, the two main areas that require attention are detection sensitivity and overall analysis time. The system was shown to be able to detect dichlorvos, omethoate and malaoxon present in wheat at 5 mg/kg. This is quite high and is typically around or above the MRL for many pesticide/cereal and greater than MRLs for many pesticide/fruit combinations. It will be essential to be able to detect lower concentrations, since, if pesticide is present, most food companies will want to know actual level in addition to whether it is legal (i.e. below the MRL). It is likely that lower detection limits can be achieved, as earlier electrode/pesticide calibration studies at UWE using different batches of electrodes and model solutions showed detection down to 100 µg/kg (i.e. 0.1ppm) was possible.

The prototype instrument is easy to use operate (i.e. single button operation), but analysis time needs to be reduced from the present 25 minutes (i.e. 10 minutes for extraction and 15 minutes for instrumental determination), if the instrument is to find widespread application in food intake environments. Solvent delivery could be enhanced by use of a pumping system that delivers samples and reagents to each cell simultaneously, rather than sequentially as at present. A simplified handling and docking system for the electrodes would also help to shorten analysis time needed for electrode loading.

Conclusion

In principle, the two key technologies (i.e. rapid extraction and biosensor detection) could be used as a platform to develop methods for the detection and determination of other food contaminants.

Publication arising from project

Poster Presentations

1. Wedge, R., Hart, J. P., Marty J. L., Fournier, D. and Millner, P. (2002). An Amperometric Biosensor Array To Measure Organophosphate Residue Concentrations in Raw Produce. Biosensors 2002, Elsevier Science, Kyoto, Japan.
2. R. Wedge, J.P. Hart, J.L. Marty, D. Fournier and P. Millner (2002). Studies Towards An Amperometric Biosensor Array To Measure Organophosphate Residue Concentrations In Raw Produce. Electrochemistry Group Faraday Division and Electroanalytical Group Analytical Division, Royal Society of Chemistry, and Electrochemical Technology, Society of Chemical Industry. University of Central Lancashire, Preston.
3. Crew, R. Wedge, J.P. Hart, J.L. Marty, D. Fournier & P. Millner (2003). An Amperometric Biosensor Array To Measure Organophosphate Concentrations In Raw Produce. Electrochemistry Group Faraday Division and Electroanalytical Group Analytical Division, Royal Society of Chemistry, and Electrochemical Technology, Society of Chemical Industry, University of Portsmouth, 14-17th September.
4. Crew, R. Wedge, J. P. Hart, J. L. Marty, D. Fournier and P Millner (2003). An Amperometric Biosensor Array To Measure Organophosphate Concentrations In Raw Produce. Biosensors for Food Safety and Environmental Monitoring workshop in Marrakech, October 9-11, 2003.
5. A. Crew, R. Wedge, J.P. Hart, J.L. Marty, D. Fournier & P. Millner (2004). An Amperometric Biosensor Array To Measure Organophosphate Concentrations In Raw Produce. To be presented at Biosensors 2004, Elsevier Science, Granada, Spain.
6. Vakurov, C.E. Simpson, C.L. Daly, T.D. Gibson, P.A. Millner (2003). Immobilization and stabilization of AChE on carbon electrode in biosensors for pesticide detection. Synthetic Receptors conference, October 2003 in Lisbon

Full Refereed Papers

1. Crew, A., Wedge, R., Hart, J. P., Marty, J. L. Fournier, D. (2004). A Screen-printed, Amperometric, Biosensor Array for the Detection of Organophosphate Pesticides Based on Inhibition of Wild Type, and Mutant Acetylcholinesterases, from *Drosophila Melanogaster*, Anal. Letts. Submitted.
2. Vakourov A, CE Simpson CL Daly TD Gibson PA Millner. (2004). Acetylcholinesterase based biosensor electrodes for organophosphate pesticide detection. I. Modification of carbon surface for immobilization of acetylcholinesterase. Biosensors and Bioelectronics. In press.
3. Vakourov A, CE Simpson CL Daly TD Gibson PA Millner (2004). Acetylcholinesterase screen-printed carbon biosensor for pesticide detection. B. Immobilisation and stabilization of acetylcholinesterase. For submission in Biosensors and Bioelectronics.

Chapters in books

1. R. Luxton and J. Hart (2003) The rapid detection of pesticide residues. In: Rapid and on-line instrumentation for food quality assurance, edited by I. Tothill. Published by Woodhead Publishing.
2. R. Luxton and J. Hart (2004) The rapid detection of pesticide residues. In: Pesticides, veterinary and other residues in food, edited by D. Watson. Published by Woodhead Publishing.

Appendix

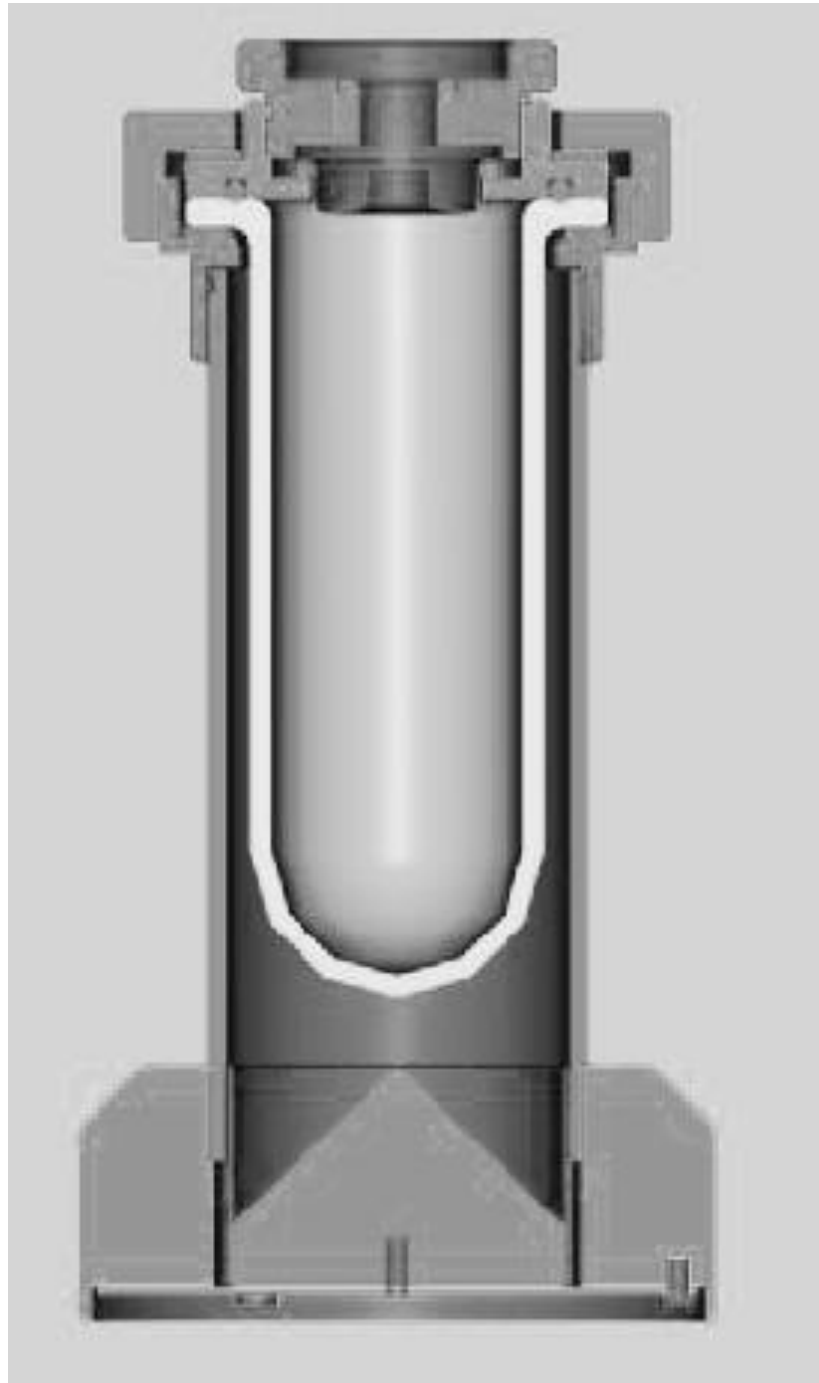

Diagram of the extraction vessel designed and fabricated for the project.